



# **Pulsonix Design System V12.5 Update Notes**

## 2 Pulsonix Version 12.5 Update Notes

---

### Copyright Notice

Copyright © WestDev Ltd. 2000-2023

Pulsonix is a Trademark of WestDev Ltd. All rights reserved. E&OE

Copyright in the whole and every part of this software and manual belongs to WestDev Ltd. and may not be used, sold, transferred, copied or reproduced in whole or in part in any manner or in any media to any person, without the prior written consent of WestDev Ltd. If you use this manual, you do so at your own risk and on the understanding that neither WestDev Ltd. nor associated companies shall be liable for any loss or damage of any kind.

WestDev Ltd. does not warrant that the software package will function properly in every hardware software environment.

Although WestDev Ltd. has tested the software and reviewed the documentation, WestDev Ltd. makes no warranty or representation, either express or implied, with respect to this software or documentation, their quality, performance, merchantability, or fitness for a particular purpose. This software and documentation are licensed 'as is', and you the licensee, by making use thereof, are assuming the entire risk as to their quality and performance.

In no event will WestDev Ltd. be liable for direct, indirect, special, incidental, or consequential damage arising out of the use or inability to use the software or documentation, even if advised of the possibility of such damages.

WestDev Ltd. reserves the right to alter, modify, correct and upgrade our software programs and publications without notice and without incurring liability.

Microsoft, Windows and Windows NT are either registered trademarks or trademarks of Microsoft Corporation. All other trademarks are acknowledged to their respective owners.

Pulsonix, a division of WestDev Ltd.

Printed in the UK Issue date: 02/11/23

### **Pulsonix**

20 Miller Court  
Severn Drive  
Tewkesbury  
Glos  
GL20 8DN  
United Kingdom

Support Phone +44 (0)1684 296 570

Sales Phone +44 (0)1684 296 551

Email [sales@pulsonix.com](mailto:sales@pulsonix.com)

Web [www.pulsonix.com](http://www.pulsonix.com)

# Contents

<b>CONTENTS .....</b>	<b>3</b>
<b>VERSION 12.5 UPDATE SUPPLEMENT .....</b>	<b>7</b>
Installing the New Version of Pulsonix .....	7
Licensing .....	7
Version 12.5 Update Notes .....	7
<b>NEW IN VERSION 12.5 .....</b>	<b>8</b>
Interactive Graphics Enhancement .....	8
Technology Changes.....	8
Export/Import CSV of Additional Rules .....	8
Suppressed Land Rules.....	9
Suppressed Pads - Additional Drill Spacing .....	9
Teardrop Rules by Layer and Area.....	10
Thermal Rules by Layer and Area.....	10
Unplated Drill to Drill Spacing.....	10
Changes to Barcode Font.....	11
New Font Type for QR Code Generation .....	12
Force Everything Visible in Colours .....	14
Layers - Allow Micro-via Stop Pad Either Side .....	15
Spacing Rules – Mounting Hole Spacing Rule Type.....	16
Area Keep In/Out Defined by Rules.....	17
Area - Keep Exclusive .....	17
Attribute Editor Changes .....	18
Dialog Reorganisation .....	18
Show Empty Columns .....	18
CSV Hidden option .....	18
Attribute Validation using Wildcards .....	19
Tear-Off Windows.....	19
Make Selected Items Visible in Cross-Probe Mode.....	21
Dynamic Cross-Probe Mode.....	21
Dynamic Cross-Probe Mode – Centre View On Probed Item.....	22
Save/Load Partial Configuration Files.....	22
Current Document Directory as a Folder .....	23
Folders - Include Subfolders.....	23
Undo History and dropdown list.....	24
3D Space Mouse Support in PCB and SCM Editors.....	24
3D Design Changes .....	24
3D Design Menu Changes .....	24
Dynamic Flexi Board Folding Overview .....	25
3D Flexi Board Folding Settings .....	29
Changes to Insert Board Origin .....	30
Insert Flex Bend Line .....	31
Comp/Via Keepout Areas in 3D Viewer .....	33
Flex Bend Regions DRC .....	35
True Folded Board Status used in STEP Output.....	36
Changing STEP Colours No Longer Regenerated For 3D Viewer.....	36
Output STL File.....	36
Output As A Single Merged Entity.....	37

## 4 Contents

---

Updated 3D Viewer Functionality .....	38
Use STEP Model as Enclosure .....	39
Improved Performance for Position STEP Model Rotations .....	39
Interactive Rotating Changes in Position STEP Model .....	40
STEP Model Alignment and Snap by Centre .....	40
New Trihedron Axis View Cube .....	42
Additional Spotlight .....	43
3D Settings – Show Drill Holes for Enabled Items Only.....	44
Footprint Moves with Component.....	44
Find Bar Changes .....	44
Find Unpoured Templates .....	44
Insert Text – Select Text Style.....	45
Highlight List from Design Selection .....	45
Insert Component - Find a Part by Schematic Symbol Name.....	46
Parts Library .....	46
Splitters added to Part Editor.....	46
Edit Symbol available from Preview window .....	47
Connector Part – Different Symbol Name on Pins .....	48
New Pin Types for Ancillary Pads and Mounting Holes .....	49
Reload From Library - Match Gates by Pin Names in Schematics .....	51
Check for a Single Signal Refs in ERC in Schematics .....	52
Unmatched Signal Refs in ERC in Schematics.....	52
Insert Connector Pin - Copy Previous Pin option .....	52
Change Mounting Hole to Pad.....	53
Change a Normal Part to a Connector.....	53
Inspector Bar Changes .....	54
Change Group Order dialog improvements .....	54
Block Groups in PCB Designs.....	55
Execute Hyperlink in Attributes grid.....	55
Component Bin Changes .....	56
Show Pre-defined nets on Single Pin Items in the Bin.....	56
Highlight Components on Marked Net in Bin .....	56
Bin Filtering.....	57
Bin Sorting.....	57
Drag Out of Bin Ordering.....	57
Bus Properties – Report button .....	58
Rename Sub-net in PCB using Change Net.....	58
Auto-Rename - change a Prefix or Suffix .....	60
Changes to Edit and Add Wire Functionality .....	60
Changes to Apply Vias option .....	61
Wire Defaults – Line Angle.....	62
Bitmap Scaling Changes.....	62
Mirror Vertically.....	63
Apply layout pattern .....	63
Copy Copper With Template.....	63
Remove Peripheral Items.....	64
Cut Shape.....	65
Improved Wave Shape Generation .....	69
Construction Line Changes.....	70
New Construction Line Shapes.....	70
New Non-infinite Construction Line option .....	70
Change Shape to Construction Line .....	71
Clip Construction Lines.....	71
Edit Shape Using Construction Lines .....	73

Add Construction Line Along Segment(s).....	74
Set Tangent Angle .....	75
Snap to Construction Line - Vias.....	75
Named Construction Lines .....	76
Divide Circle by an odd number.....	76
CAM Plot Changes.....	77
Plot Transformations in CAM Plot Preview .....	77
Splitter Control in CAM Plot Preview .....	78
Gerber Plot File Extensions .....	79
PDF Plot - Zoom on a Clickable Link .....	79
PDF Plot - Customise Drilled-Out Pad Line Width.....	79
DXF Output – Save settings .....	80
GenCAD Output .....	80
Multi-Threading use for Processing GenCAD Files.....	80
GenCAD Settings Saved.....	80
GenCAD Dialog Rearranged.....	81
Select Output by Layer or Layer Class .....	81
Output Board Level Mounting Holes Class .....	82
Output Current (or Named) Variant.....	82
Panel Editor .....	82
Interaction Options .....	82
Apply Tab-Rout to All Instances .....	83
Double Row Mouse Bites.....	83
Intelligent Gerber Import – New Data Type - Placement CSV.....	84
Generate Component Dialog improvements.....	85
PDC Database Bar – Splitter Controls Added.....	85
Variants.....	86
Doc Shapes .....	86
Multiple Select Fitted/Not Fitted Components .....	86
Vault Changes.....	87
Underlying Vault Technology Changes.....	87
Updated ODBC Driver .....	88
Updated Vault Setup ODBC Drivers.....	88
Updated Vault Postgres Server to V14.5 .....	90
Vault Database Update .....	90
Vault Column Sorting.....	93
Sign Out from Vault .....	94
Changing Vault Column Order.....	94
Splitter Controls in Browser Window.....	95
‘Generic’ Files with Vault .....	95
Transfer Library Data to Vault – New Data Types.....	96
Find Components by Footprint or Symbol in Vault Speed-up.....	97
Show Attributes from Vault Browser .....	97
Filter Capability Added to the Check Out from Vault Dialog .....	98
Execute Attribute Hyperlink.....	98
Check-Out / Copy-Out Vault item using the Vault Toolbar Preselects The Item.....	99
Import Libraries to Vault .....	99
PLM Command File Interface for the new Import Vault Libraries option.....	100
Vault Attribute Colours .....	100
Library ToolKit Changes.....	101
Report Maker Changes .....	101
Network License Server Manager.....	104
Disconnect All Clients.....	104
Disconnect All Clients via Configuration File.....	104

## 6 Contents

---

Scripting Changes .....	104
Progress Indicator on Taskbar Icon.....	106
Dynamic Design Verify Improvements .....	106
Enable Dynamic Verify .....	106
Memory Dumps.....	108

## Version 12.5 Update Supplement

### Installing the New Version of Pulsonix

It is always recommended you back-up all libraries, designs, technology files, profile files and report files before installing the latest version. Other than for any technical reason, this is good working practice, although you should already have a backup of this data!

To install Pulsonix, double-click on the download executable and wait for a short time. You may have been supplied a CD, in which case insert it and wait for it to run. The *Autorun* facility will start the installation procedure. Follow the on-screen commands from the install wizard. You can install Pulsonix 12.5 over your existing V12.0 installation. If upgrading from V12.0, you can install it alongside the older version if you prefer. In any case, you do not need to uninstall the old version first unless you wish to remove it from your hard drive.

#### 64-bit Installation Folder

By default, Pulsonix V12.5 will be installed into the programs folder **C:\Program Files\Pulsonix12.5** rather than C:\Program Files (X86) which is where the 32-bit applications are installed.

#### Documentation Installation

The default installation locates all Pulsonix 'documents' (Master Libraries, Technology files etc.) is under user\documents\Pulsonix12.5 rather than being placed in public documents\PulsonixXX

### Licensing

Version 12.5 requires a new license if you are a new user or upgrading from any older version of Pulsonix earlier than and including V12.0. The new license would have been supplied to you under the terms of your maintenance contract.

For existing users upgrading from a previous version, it is recommended that you save the new license in the same location as the current one but make a backup copy first or rename it. When requested during installation, simply click the **No Change In Licensing** check box on the licensing page of the installation wizard. The **License Manager** can be used to add new licenses and make changes to network licensing after the installation has been completed.

### Version 12.5 Update Notes

The **Version 12.5 Update Notes** are available in the Pulsonix product installation folder under \documents. Alternatively, select the direct link within the product itself: **Help** menu | **Online Manuals> Pulsonix V12.5 Updates Notes**. You can also find them on the Pulsonix web site. The set of notes on the web site will be more up-to-date than the installed version as we are constantly updating these.

The current and all previous Update Notes are available on the Pulsonix web site under **Documentation**.

# New In Version 12.5

## Interactive Graphics Enhancement

An enhancement to the new fast graphics package introduced at V11.0 and V12.0 has been added for V12.5 for interactive (dynamic) functions, such as Component Select/Move, Text Select/Move etc.

There is a new switch in **Options, Display** called **Use for Dynamic Items**. When selected, this will enable any dynamic item, such as when editing a track or moving a component or text, to be redrawn using the enhanced GPU graphics.

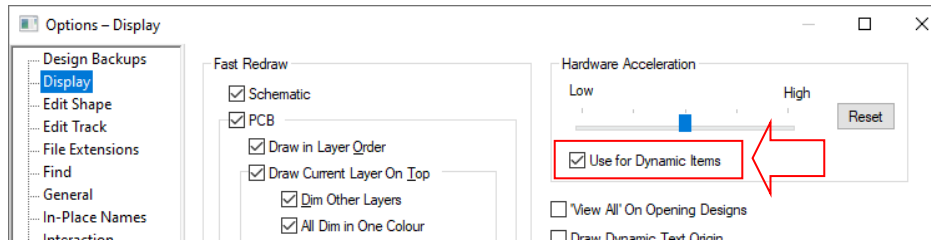

## Technology Changes

### Export/Import CSV of Additional Rules

New **Export CSV** and **Import CSV** buttons have been added to the **Technology** dialog for: **Spacings Design Level, Spacings Net Class Level, Spacings Match Pair Level, Rules High Speed Differential Pairs** and **Nets Signal Paths**.

In addition, the **Export CSV** and **Import CSV** buttons have been added in a **Panel Design** to the **Technology** dialog to the **Spacing Design Level Panel** tab.

Existing button on **Spacings Net Class Level (Import CSV)** has been renamed to **Custom CSV Import** to allow for the new Export/Import CSV functionality.

---

*Note, the existing **Custom CSV** option is very specific to particular customer data for import. This import allows field customisation. For general CSV import, use the new **Import CSV** option. There is no equivalent **Export CSV** function for this option.*

---

Having this functionality allows the additional rules to be exported to a template and then imported to create the rules/data once edited.

*This feature was back-fitted to V12.0.8944.*



## Suppressed Land Rules

Suppressed Lands are now defined by rules, instead of being defined on the layer. Use the new **Suppress Land Rules** page under **Technology** and **Rules DFM/DFT**

Enable	Attribute Name	Match Value	Side	Layer	Area	Applies To					Suppress Land
						Through Hole Pad	Via	Micro-via	Through Mounting	Inner Only	
<input checked="" type="checkbox"/>	<Net Name>	Gnd	Inner			<input checked="" type="checkbox"/>	<input checked="" type="checkbox"/>	<input checked="" type="checkbox"/>	<input checked="" type="checkbox"/>	<input checked="" type="checkbox"/>	<input checked="" type="checkbox"/>

Attribute:

Match:

On Layers

Side:

Layer:

Within Areas:

Suppress

Inner Only

Apply To:

Through Hole Pad

Vias

Micro-vias

Mount Holes

This page offers more flexibility in that a rule can be defined for an **Attribute**, including **Net Names**, and for **Layers** and **Areas**.

There is also a separate option to override the land suppression when on the **Inner Only** (not top or bottom) layers of the span.

## Suppressed Pads - Additional Drill Spacing

Within the **Technology** dialog under **Design Level Spacings** and the **Pad** tab, there is an additional rule **Additional Drill Spacing**. This can be used to determine if a pad can be suppressed when adjacent to copper on the same net. This spacing is the minimum distance between the drill hole and copper on the same net, before the pad will be suppressed. When set, this is used to provide an additional spacing (over the drill to copper), before the pad is considered suppressed.

Additional Design Level Spacings and Rules:

Board
Bond And Die Pad
Component
Copper
Drill
Pad
Text
Track
Enclosures

Minimum Pad Land

Pad Type:

Radius Difference

Radius Percentage

Absolute Area

Suppressed Pads

Additional Drill Spacing:

Check suppressed pads as though pad is there

Use suppressed pad spacing shape

*This feature was back-fitted to V12.0.*

## Teardrop Rules by Layer and Area

Under **Technology, Rules DFM/DFT and Teardrops**, you can now define **Teardrop** rules for **Layers** and within a named **Area**.

Attribute: <Net Class Name> ▾  
Match: \* ▾ ✖

On Layers:  
Side: <Any> ▾  
or  
Layer: ▾

Within Areas: ▾

V Angle: 60.0

Shape: Triangle ▾

Use Length: 0.000

Apply Teardrops To:  
 Through Hole  
 Surface Mount  
 Vias  
 Micro-vias  
 Round Pads Only

## Thermal Rules by Layer and Area

Under **Technology, Rules DFM/DFT and Thermal**, you can now define **Thermal** rules for **Layers** and within a named **Area**.

Attribute: <Net Name> ▾  
Match: \* ▾ ✖

Applies To: Any ▾  
Min Pad Size: 0.000 ▾

On Layers:  
Side: <Any> ▾  
or  
Layer: ▾

Within Areas: ▾

Connect Type: Thermal Pad ▾

Enclosed Pads Only:

Orthogonal Spokes:

Isolation Gap: 0.254

Number Of Spokes: 4 ▾  
Minimum Spokes: 2 ▾

Try Alternative Rotation:   
Rotate With Pad:

First Spoke Angle: 0.00

Spoke Style: 0.127

<Thermal Relief Spokes> ▾

## Unplated Drill to Drill Spacing

Under **Technology, Spacing Rules, Design Level and Drill**, an **Unplated** spacing has been added to the **Drill To Drill Space** rule. This is only applied between unplated drill holes (normal drill spacing is applied between plated and unplated holes). In particular, Back Drills are unplated.

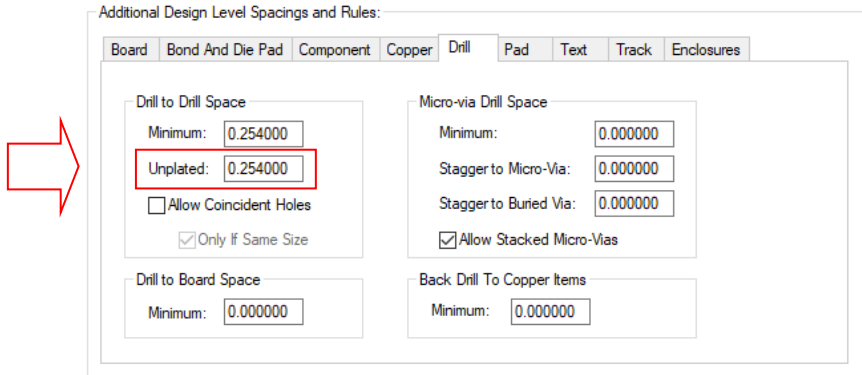

### Changes to Barcode Font

The Barcode font style has been changed to bring it inline with the font style used for QR codes.

**Previously**, the barcode barring and gaps were defined with the font style, as below:

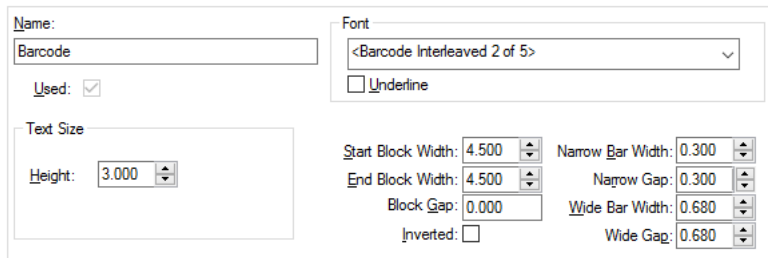

Changes to the dialog mean that you now define the **Name**, the **Font** (using **<Special Font>**) and the **Special Font Type** from the list. You then use the **Manage** dialog to define the font parameters.

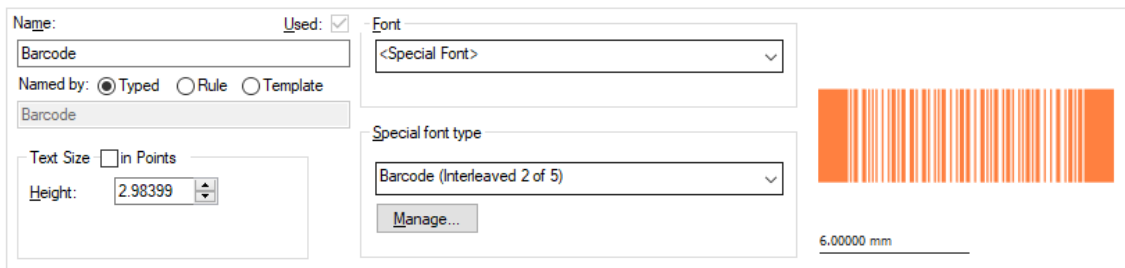

Any existing Barcode font types in your design or Technology file will be converted to this new style along with their parameters.

*See below for a full description on using the new functionality.*

### New Font Type for QR Code Generation

In addition to the existing ability to add a QR code as a **bitmap**, you can now generate QR codes in Pulsonix using a new <Special Font> **Font style**. The advantage of this over a QR code bitmap is that the font can be added to electrical layers whereas a bitmap cannot be.

When adding a QR code using this new font, the QR code is generated by Pulsonix based on the text you enter.

The QR font must first be defined in the **Technology Text Styles** dialog using the new <Special Font> font style. Then select the **Special Font Type** to inform it which font to use (Barcode or QR Code).

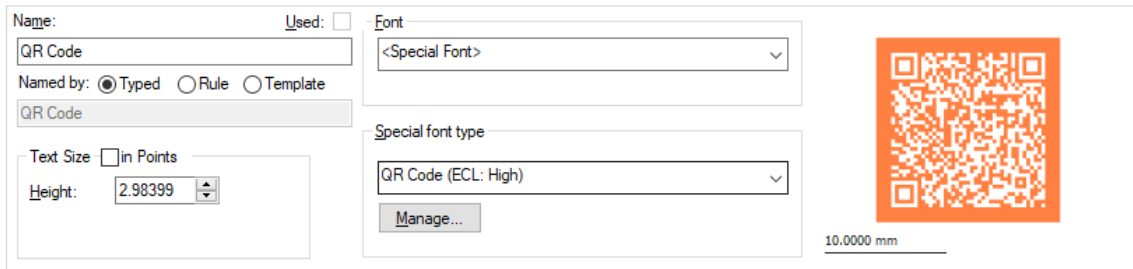

The **Manage** button is used to define the style of the Barcode or QR Code.

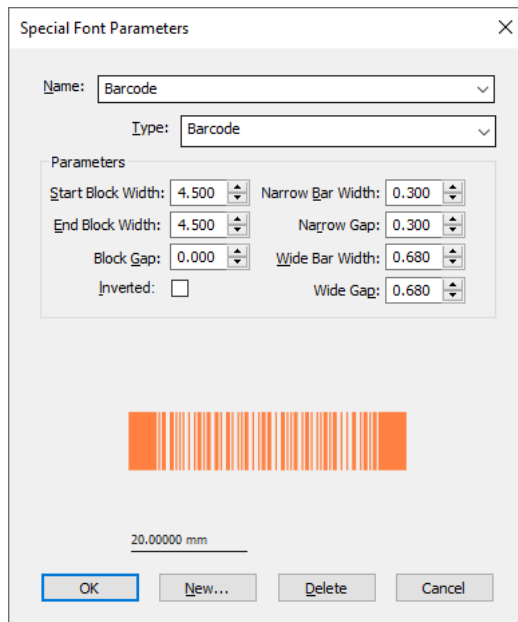

As before, the parameters are the same.

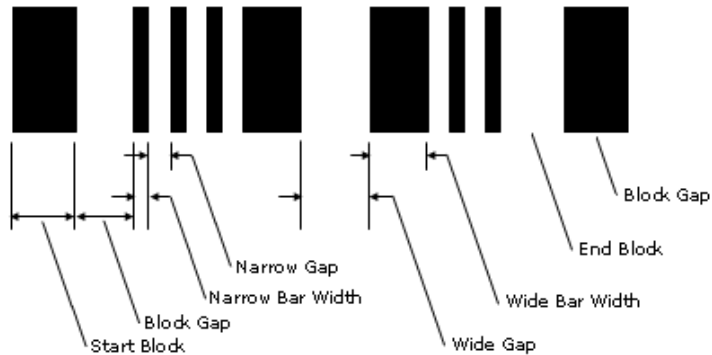

The dialog changes for defining a QR Code:

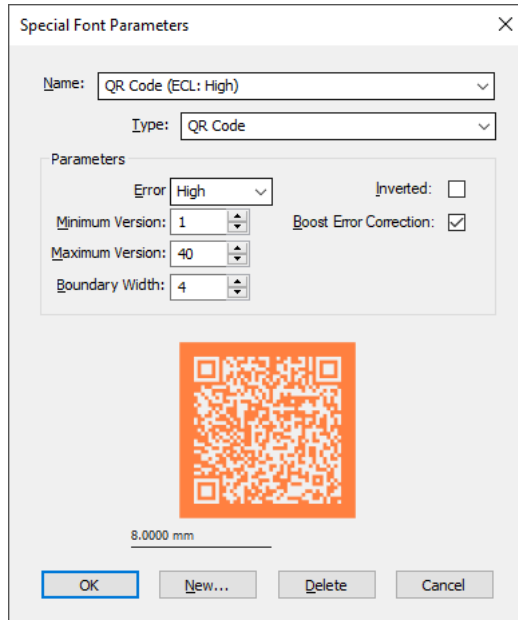

QR codes can be used to encode alphanumeric text. Their parameters include:

Error correction, determines the proportion of codewords in the QR code that can be damaged for the QR to still be readable. This will effect the size (version) of the generated QR code.

- Low - 7%
- Medium - 15%
- Quartile - 25%
- High - 30%

**Minimum & Maximum Version** The QR standard supports 40 versions based on their size. e.g. version 1 QR codes are 21x21, version 2 are 25x25 etc.

**Boundary Width** the width in squares surrounding the QR code.

**Inverted** is the QR code inverted.

**Boost Error Correction** improves the error correction of the QR code without increasing its version (size) if possible.

### Using Special Fonts

Like existing Barcode fonts, QR fonts can be selected by name once the style name has been defined. QR codes work in the same way as Barcodes by using numbers, but also real web site URLs can be used such as [www.pulsonix.com](http://www.pulsonix.com)

### Text Styles Dialog

If you use a Text Styles dialog, from Properties for example, or anywhere that you can change a text style, such as Change Style, you can select the new font <Special Font>. By selecting it, an additional combo box is displayed with preset parameters like Barcode (Interleaved 2 of 5), QR Code (ECL: High) etc.

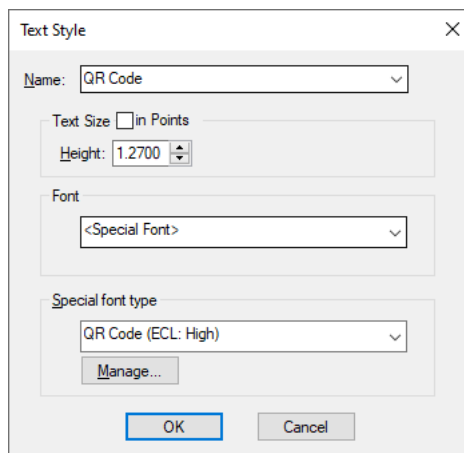

## Force Everything Visible in Colours

### Force Everything Visible

You can now force everything to be visible (Displayed), Selectable or True Width by selecting the **Force Everything** check box in the **Colours** dialog and **Others** page. This means you can use one of these settings for everything without disturbing any other colour settings you have set. This sets everything **except** Attribute Positions (see below).

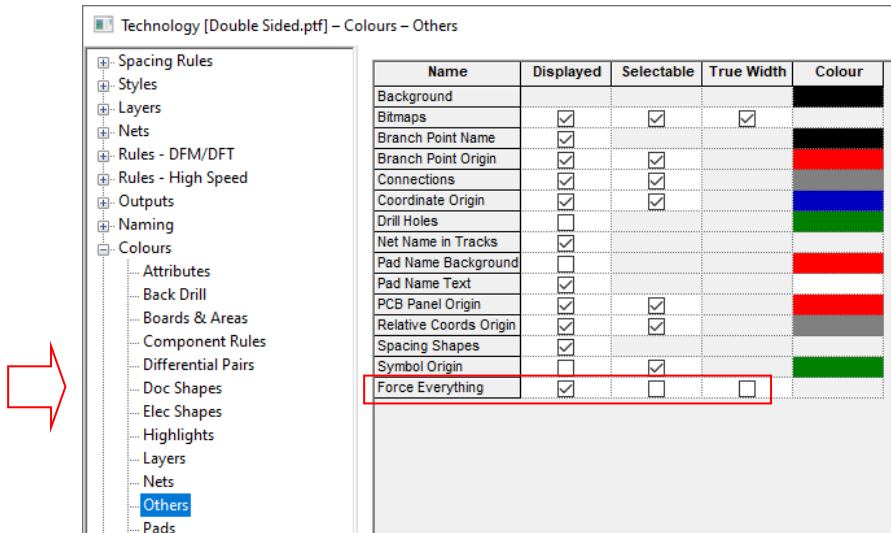

This switch is available in all editors in Pulsonix, including Schematic, Symbols, PCB, Footprint and Panel Editors.

### Force Display Of Attribute Positions

This check box enables you to force your attribute positions on. This is independent of the **Force Everything** setting in the **Colours - Others** dialog.

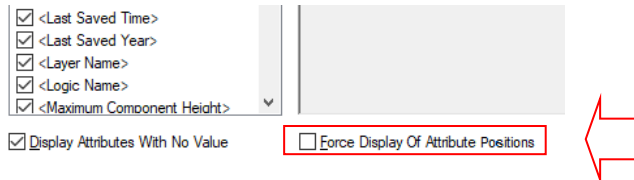

### Layers - Allow Micro-via Stop Pad Either Side

A new check box on inner electrical layers, **Allow Micro-via Stop Pad Either Side**, allows you to create micro-vias onto the electrical layer from above or below, regardless of the facing value of this layer. You should only use this if you really know what you're doing and following consultation with your manufacturer.

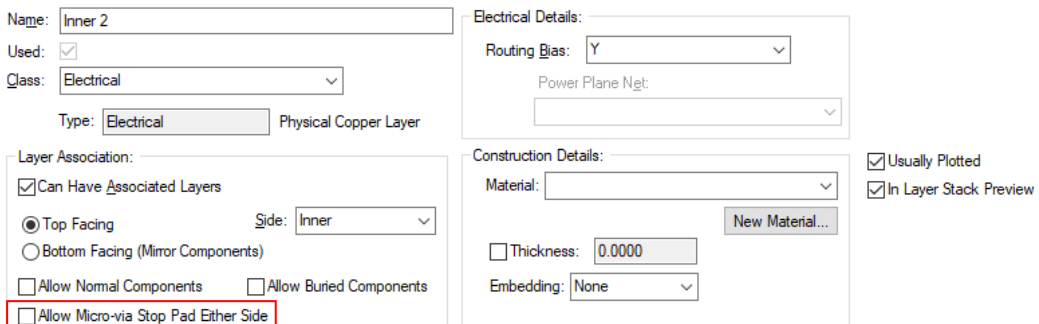

Using this setup enables a layer span like this to be created where a Micro-via can be added as top facing but will span to a bottom facing layer.

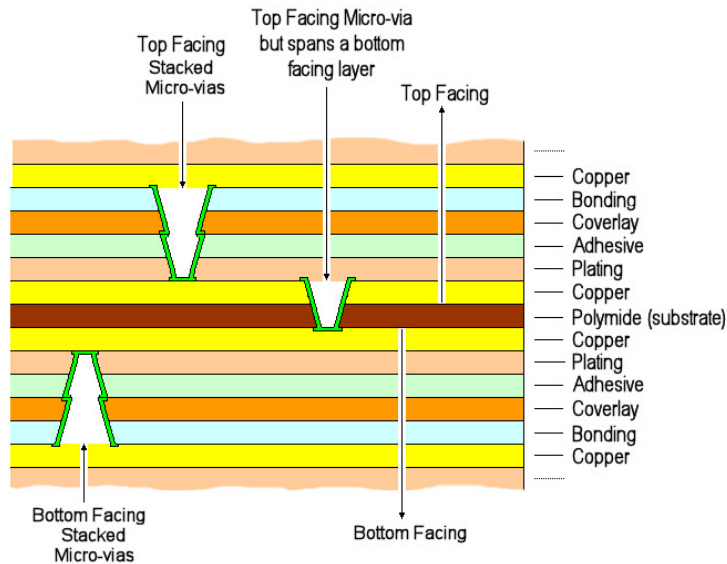

## Spacing Rules – Mounting Hole Spacing Rule Type

There is now an option to determine if an SMD Mounting Hole is treated as a Mounting Hole or an SMD Pad.

From within **Technology**, **Spacing Rules**, **Design Level** and **Pads** tab, there is new check box, **SMD Mounting Hole as SMD Pad**. Check this option to cause design rules checking to use the **SMD Pad** spacings for a **SMD Mounting Hole** (i.e. a mounting hole that is only on one side of the board and not drilled). Otherwise, an SMD Mounting Hole uses the spacings for a **Mounting Hole**.

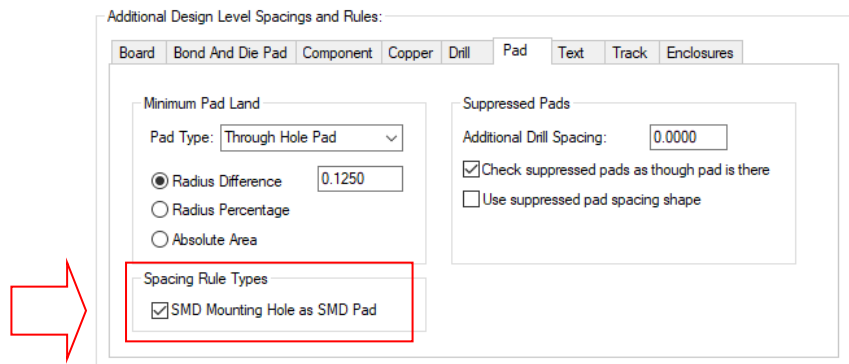



## Area Keep In/Out Defined by Rules

**Area Keep In/Out** can now be defined by rules within the Technology under **Rules, DFM/DFT, Area**. This in addition to being explicitly defined on an Area.

The advantage of this mechanism is that you can define one rule that covers many Areas in your design, rather than creating individual rules on each Area, such as a named area within a footprint.

Attribute: <Net Name>

Match: HV

On Layers

Side: <Any>

Layer:

Within Areas:

Keep In/Out

Track	Unrestricted	Testpoint	Unrestricted
Via	Unrestricted	Drill	Unrestricted
Micro Via	Unrestricted	Copper	Unrestricted
Component	Unrestricted	Copper Pour	Unrestricted
Component Pad	Unrestricted	Power Plane	Unrestricted
Component Mount Hole	Unrestricted		

Additional new definitions are available for rules:

**Keep Exclusive** - the rule defines the matching areas as **Keep Out**, except for tracks or Vias on tracks which originate from a pad in the area. This rule type is only available for Tracks, Vias or Micro-vias

**Lift Restrictions** - the rule removes any **Keep In or Out** restrictions defined in **Area Properties** on the matching areas.

**Unrestricted** on a rule means no further restrictions (for that type of item). By default, areas have no restrictions, which would mean all restrictions are controlled by the rules.

## Area - Keep Exclusive

For **Tracks** or **Vias**, you can define an area as **Keep Exclusive**. This keeps out **Tracks** or **Vias**, except for tracks or vias connected with a track which originates from a pad inside the area.

Properties: Area - Area

Segment Shape Line Style Area Area Attributes

Name:   Design Extents

Keep In/Out

Tracks **Unrestricted**  Copper Keep Out  Drill t

Vias **Unrestricted**  
Keep In  
Keep Out

Testpoints **Keep Exclusive** Mount Hole Unrestricted

Component Pads Unrestricted

Components Unrestricted If Higher Than:



## Attribute Editor Changes

### Dialog Reorganisation

The **Edit Attribute** dialog has been slightly reorganised. The **Save Columns** button has been renamed to **Save** and the **Column Visib** button has been renamed to **Visibility**, and both buttons have been moved inside a **Column** group.

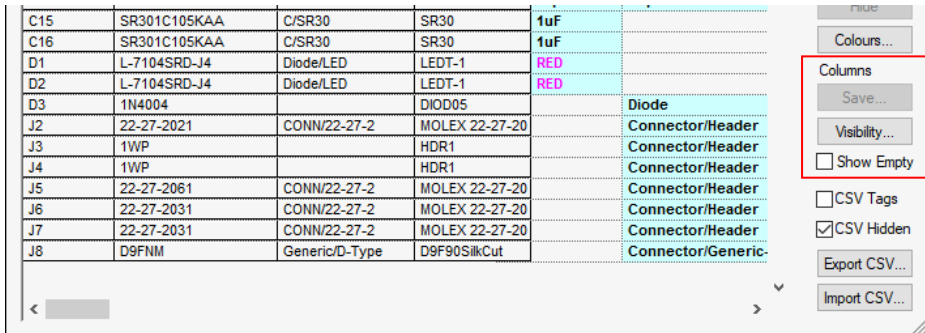

### Show Empty Columns

A new check box has been added inside the **Column** group named **Show Empty**. Enabling this option will show all empty columns in the grid (provided they are enabled in the **Visibility** dialog), and disabling the option will hide empty columns.

*This was backfitted to V12.0.*

### CSV Hidden option

The **Attribute Editor** now has an extra check box, **CSV Hidden**. Check this to have Export CSV to include all hidden columns in the output (this is how it worked prior to this option being added) and uncheck it to only output columns that are not hidden (this switch is checked by default).

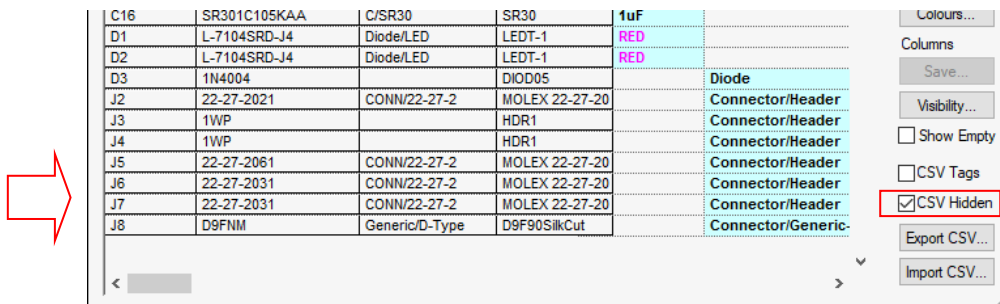

*This feature was back-fitted to V12.0.*

## Attribute Validation using Wildcards

### Matched String is no longer than a specified length

You can use **%I4** (or other number than 4) to ensure that the remainder of the matched string is no longer than the number of characters specified (4 in this example). The letter 'L' must be **lower** case.

### Matched String is exactly a specified length

You can use **%L10** (or other number than 10) to ensure that the remainder of the matched string is exactly 4 characters long. The letter 'L' must be **upper** case.

As an example of using this new wildcard, you could define **%L10%iL%#** which will ensure that the remainder of the string (in this case the integer) is exactly 10 characters long.

## Tear-Off Windows

A new option is available in the **Options, Multi-Screen** settings that will enable **Tear-Off Windows**. A restart of the program is required to activate it once selected (or deselected).

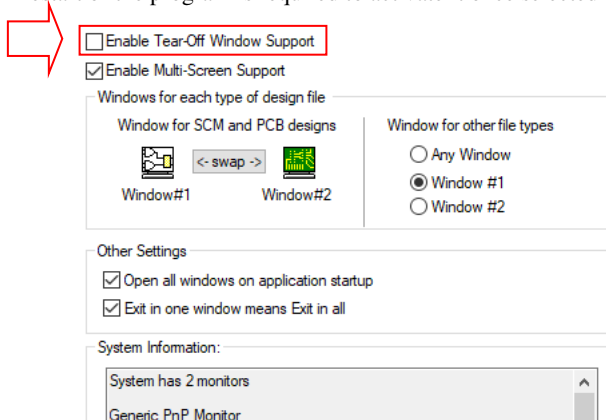

Tear-off windows are used as an alternative to Multi-screen and are capable of supporting more than two screens (unlike Multi-Screen which is only two screens). Once ripped off they can be positioned on any screen or along side the main Pulsonix window. You could have a set of schematic sheets in one screen and the PCB design in another and cross-probe between them for example.

### Tearing off tabs

Once activated (in **Options, Multi-Screen**), tabs can be dragged off the window to create a torn off instance of Pulsonix which contains the tab. Simply drag the tab wish to have as another window. An additional benefit of this mode is that the exact order and locations of tabs/windows is saved when closing and reopening Pulsonix.

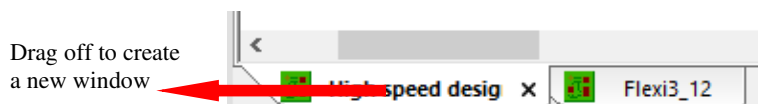

This can be done as many times as you want, so long as there is at least one tab in each window. The main frame Pulsonix window has toolbars and dock bars available.

## 20 Pulsonix Version 12.5 Update Notes

To reinstate the tabs, simply pick and drag the external window by the tab and release it onto the main framework. During this time, the main window will turn blue to indicating the window can be re-docked:

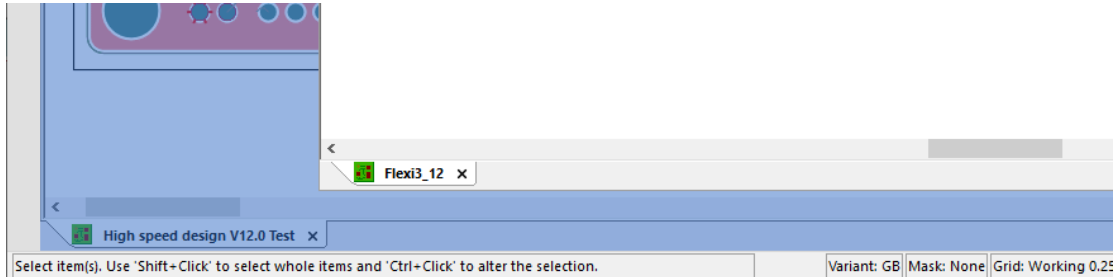

Once you are using the tear-off screen mode, you'll notice that the small 'windows' icons on the framework for Minimise, Full screen and Close are no longer available.

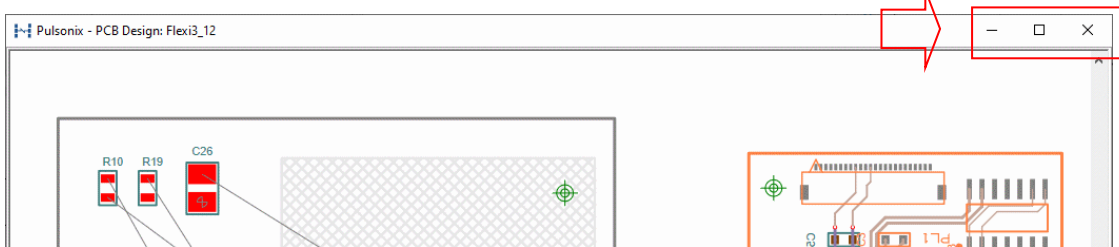

The tear-off windows are sized as required so the only option really required is the Close button. This is now available on the workbook tab as an additional **X**.



Additionally, tabs can be put into groups by dragging a tab to the edge of the screen where the scroll bars are located to create a new group. This is useful for putting designs side by side more easily.

With tabs docked in the main framework, if you right click on a tab, you can create new **Horizontal** and **Vertical Tab Groups** using the options available

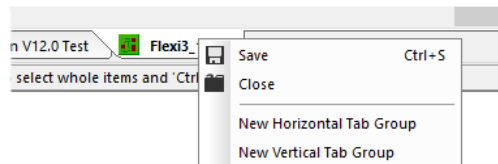

## Make Selected Items Visible in Cross-Probe Mode

There is a new setting on the **Options** dialog under **Interaction** and **Cross Probe** called **Make Selected Items Visible**.

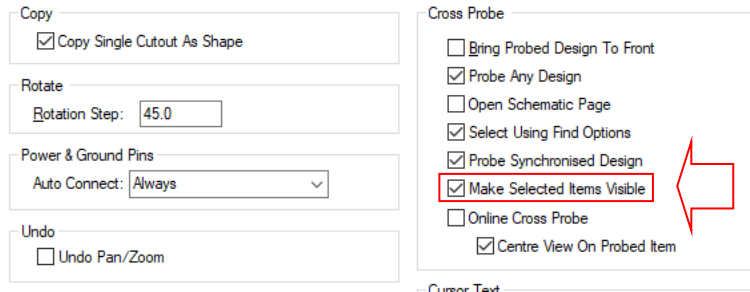

When this option is checked, any selected items in the design (selected via cross-probe) will attempt to become visible and turn on their layer so they can be seen following the probe. The default is for this to be enabled (to always make visible).

With this option unchecked, layers will not be switched on (or redrawn) which is helpful for very large designs where one might not want layers toggling after a cross-probe.

## Dynamic Cross-Probe Mode

There is a new setting on the **Options** dialog under **Interaction** and **Cross Probe** called **Online Cross Probe**. When selected, this will enable automatic Cross Probe while selecting items. All cross-probing then carried out will be in real time dynamically.

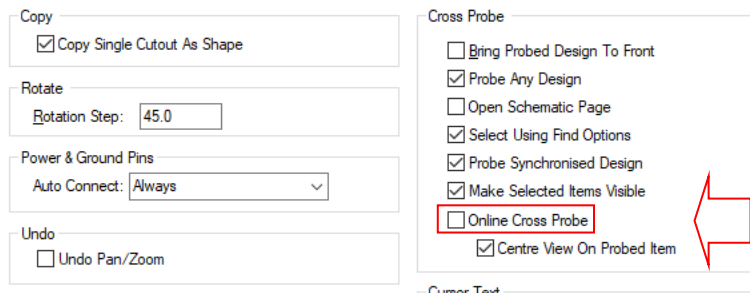

This also works in multi monitor mode and tear-off window mode.

### Dynamic Cross-Probe Mode – Centre View On Probed Item

There is a new setting on the **Options** dialog under **Interaction** and **Cross Probe** under **Online Cross Probe** called **Centre View On Probed Item**. When enabled, selected items from an online cross-probe can be centred on the view in the other design to make it obvious where the selected item is.

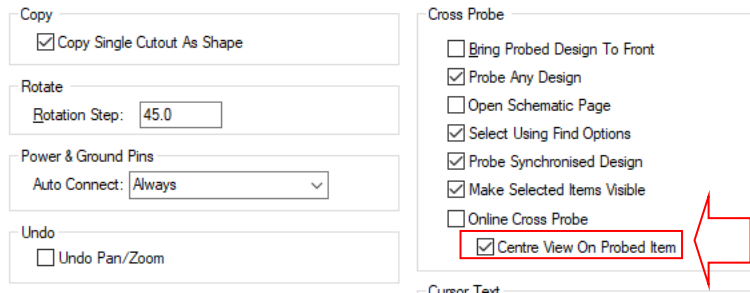

### Save/Load Partial Configuration Files

#### Underlying Technology

The underlying technology used to save/load the configuration file has been changed so the performance is greatly improved particularly when loading.

Old Configuration files will still read in but these will not utilise the new, faster mechanism.

#### Save Configuration

On selection of **Save Configuration** file (from the **File** menu), this option now displays a dialog allowing you to choose between a complete config file (all registry settings) and a partial file including only the registry branches relevant to a particular area of the application (folders, interaction, UI, etc.).

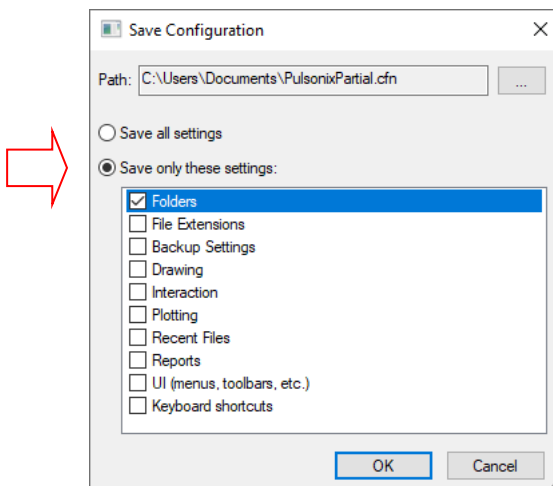

### Load Configuration

On loading a complete config file you are prompted to confirm loading the file, and given the option to save a backup file for the current registry configuration before loading the one from the file. The loaded file will then replace (rather than “overlay”) the entire PulsonixNN.N registry section.

### Current Document Directory as a Folder

You can use a dot ‘.’ as the base of a defined folder in any of the Folders dialogs to use the current document directory in place of the dot.

For example:

.\Libraries

or simply

.

These examples are both valid folders which are dynamically set.

As a working example, use this in the Libraries STEP Model Folders so that for the current design all 3D functions will collect the STEP models from the sub folder ‘STEP Models’ of the design folder.

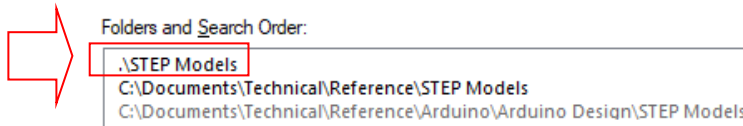

### Folders - Include Subfolders

New **Include Subfolders** check box in the folders dialog next to the **Folder Enabled** check box.

When checked, this option will recursively search through all subfolders of the master folder and add any additional files found to the list. This should aid with organisation of libraries and folders.

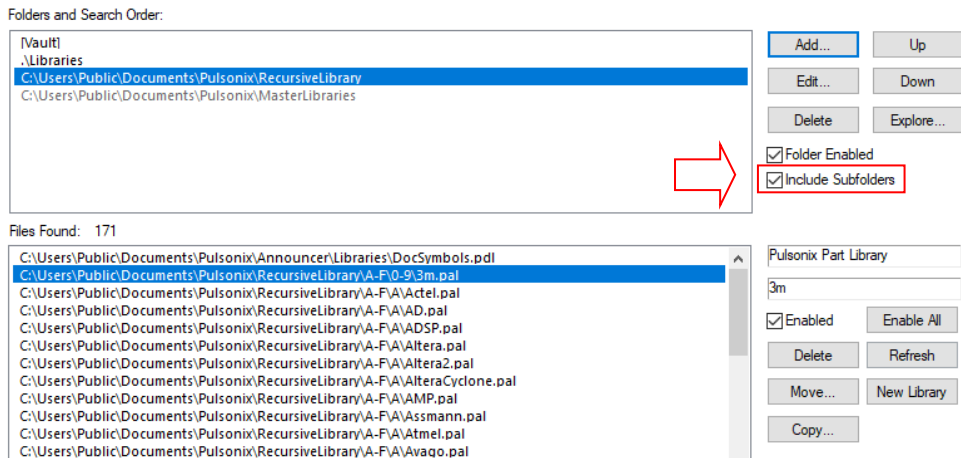

### Undo History and dropdown list

A new menu command has been added to the **Edit** menu called **Undo History**. Dropping this down will display a list which can be used to undo multiple levels in one action.

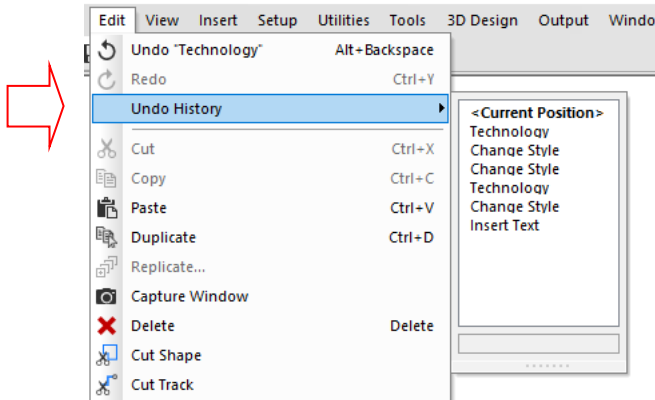

The list shows a <Current Position> which is used to more easily identify where in the undo stack you are.

The list can be used to Redo as well by clicking higher up the list after doing an undo.

### 3D Space Mouse Support in PCB and SCM Editors

Support for the 3D Connexion space mouse has been added to Pulsonix designs (in addition to existing use within the **3D Viewer** window). This will operate once the 3D Space mouse software has been installed on your PC.

It works for the pan functionality in the X and Y axis, and zoom for any native designs including Schematics, PCB, PCB Panels, Footprints and Symbols.

### 3D Design Changes

#### 3D Design Menu Changes

There has been some reorganisation and rationalisation of menu options relating to 3D Design.

#### PCB Design Editor

In the **PCB Design Editor**, the **3D Design** menu has been slightly reorganised to make it more logical and follow the order in which menu items are generally used. Also, the **Output STL** option now appears on the **3D Design** menu (see below). Other inclusions have been made to add the **Board 3D Origin** and **Bend Line** features.



Version 12.0

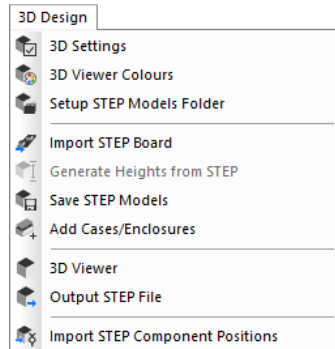

Version 12.5

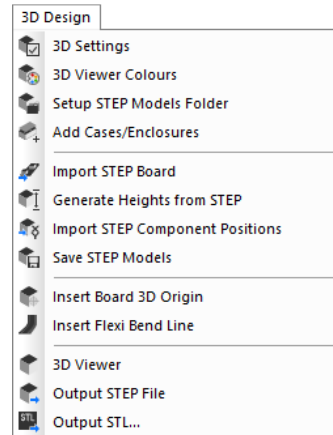

### 3D Viewer

A **3D Design** menu has been added to the **3D Viewer** to rationalise existing relevant functionality into the one menu.

In the **3D Viewer**, the **Clash detection** options, **Fold Boards**, **Fold Flexi Boards**, **Align**, **Orient** and **Rotate** have been moved off the **Tools** menu and have been added to the new **3D Design** menu. **Write STEP** file has also been moved from the **File** menu to the **3D Design** menu.

The **Measure** option has been moved to the **3D Design** menu (previously on the **Tools** menu).

The **Data Transfer** option has been removed from the **File** menu as it is not required.

### Footprint Editor and PCB Doc Symbol Editor

The **3D Design** menu has been added to both the **Footprint Editor** and **PCB Doc Symbol Editor**. Menus in these editors contain relevant functionality.

## Dynamic Flexi Board Folding Overview

Something to note before we discuss this feature is that board bending is not available when using **Exploded View**. It can only be used un-exploded.

### Board Folding Design Preparation

Below is a summary of the procedures that are required in preparing your design for folding boards. More detailed information on this can be found in the **Online Help** under the **Index** heading **Board Bending in 3D Overview**.

### Setting up Layers

You will need to ensure the correct **Layers** and **Layer Span** are in your design. An example of a simple Flexi-Rigid layer stack is in the '4 Layer Flexi-Rigid' technology include in the Pulsonix installation.

	Name	Associated Layer	Class	Side	Bias	Net
Y		Silkscreen Top	Silkscreen	Top	None	
Y	Top		Electrical	Top	X	
		Solder Mask Top	Solder Mask	Top	None	
		Paste Mask Top	Paste Mask	Top	None	
		Inner 2 - shape	Non-Plot	Inner	None	
Y	Inner 2		Electrical	Inner	X	
	Ground		Power	Inner	Power Plane	GND
		Flexi Top Assembly	Assembly	Inner	None	
Y		Flexi Top Documentation	Non-Electrical	Inner	None	
Y		Flexi Top Silkscreen	Silkscreen	Inner	None	
Y	Flexi Top		Flexi	Inner	None	
Y	Flexi Bottom		Flexi	Inner	None	
Y		Flexi Bottom Silkscreen	Silkscreen	Inner	None	
	Power		Electrical	Inner	Power Plane	+5V
	Inner 7		Electrical	Inner	X	
		Inner 7 - shape	Non-Plot	Inner	None	
Y	Bottom		Electrical	Bottom	Y	
		Silkscreen Bottom	Silkscreen	Bottom	None	
		Solder Mask Bottom	Solder Mask	Bottom	None	
		Paste Mask Bottom	Paste Mask	Bottom	None	
Y		Pin Names (Bottom)	Non-Electrical	Bottom	None	
	Documentation		Documentatio		None	
	Construction Lines		Documentatio		None	

Inner electrical layers will need to be created for the flexi span, shown below and named as Flexi layers (Flexi Top and Flexi Bottom), along with supporting documentation layers if required.

	Name	From Layer	To Layer	Type
Y	<Through Hole>	<Top Side>	<Bottom Side>	Through Hole
Y	Flexi layers	<Flexi Top>	<Flexi Bottom>	Buried
Y	Top to Flexi Top	<Top Side>	<Flexi Top>	Micro-via - top facing
Y	Top to Inner2	<Top Side>	<Inner 2>	Micro-via - top facing

### Adding Boards and Board Types

Create your required boards with the flexi board intersecting other boards so they are connected to each other. Change the Layer Span of the flexi board to be on your flexi layer span. For example (shown below with the green outlines being board and red as flexi board):

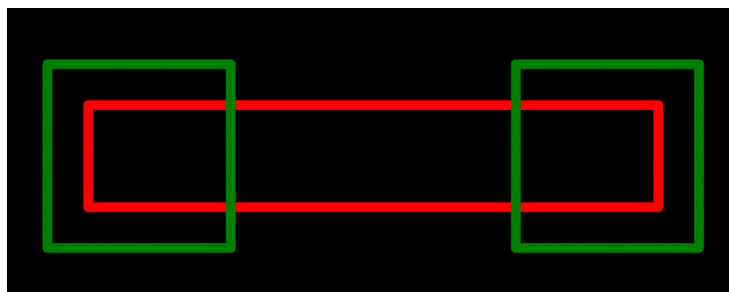

Flexi board folding works by looking at the relationship between board types, and calculates the fold and affected transformations dependent on this. Therefore, the board types need to be initially set up correctly using **Board Properties**. There are three board types in Pulsonix:

**Rigid Fixed** – a board that is fixed in position and will not be folded or transformed.

**Rigid Moving** – a board that will move based on folding flexi boards, but will not be folded.

**Flex** – a board that will be folded, and can also be transformed based on other folding flexi boards.

For a flexi board to be folded, it must be attached to a Rigid Fixed board (either directly, or attached to a moving board which is attached to a flexi board which is attached to a fixed board etc.), and can optionally be attached to one or more Rigid Moving boards. Attaching to multiple Rigid fixed boards may produce unexpected results. (Note. By 'attached' it is meant that the two boards are intersecting in the PCB view).

To change the **Board Type** of an inserted board, select the board(s) and click **Properties** on the context menu, and go to the **Board** tab.

### Adding Bend Lines

Bend lines are used to define the section of a flexi board that will be folded. A bend line is a single segment that cuts through the flexi board, accompanied by two other lines (called the **Affected Area**) offset from the main line. These two lines show the extents of the fold area, and their position are dependent on the Angle and Radius values that you can define on the bend line.

To add a bend line, click on a flexi board, right click to open the context menu, and click the Insert Bend Line option (this option is not available on rigid fixed and rigid moving boards). To start adding the bend line, click outside the board and draw the segment so that it slices through the board, and end the segment outside the board. The result should look something like this:

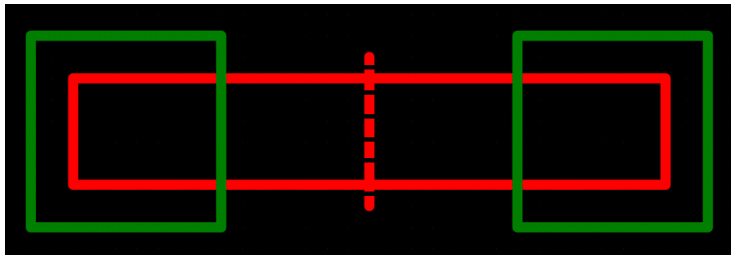

### Bend Line Properties

The bend region is defined using an **Angle** and **Radius**.

The **Angle** defines the angle at which the bend region will be folded - labelled as **theta** in the diagram below.

The **Radius** is defined as the distance away from the bend region that the centre point of the bend is located – labelled as **r** in the diagram below. The radius can be positive or negative, a positive value will fold the bend region in the positive Z direction, and a negative value will fold in the negative Z direction.

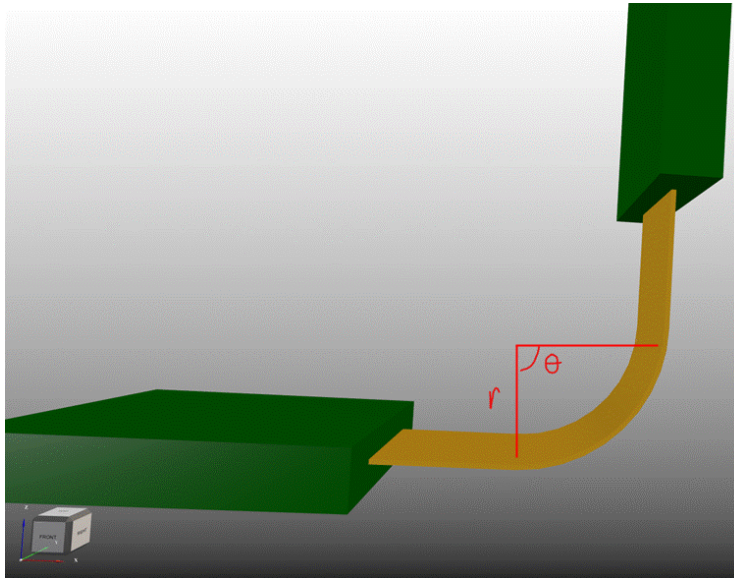

Altering the Angle and Radius will change the size of the bend region; which can be seen visually when the offset bend lines move position, or numerically by looking at the **Affected Area Width** in **Board Bend Line Properties**. This denotes the current width of the bend region.

After setting up the Bending Angle and Radius, your design should look something like this:

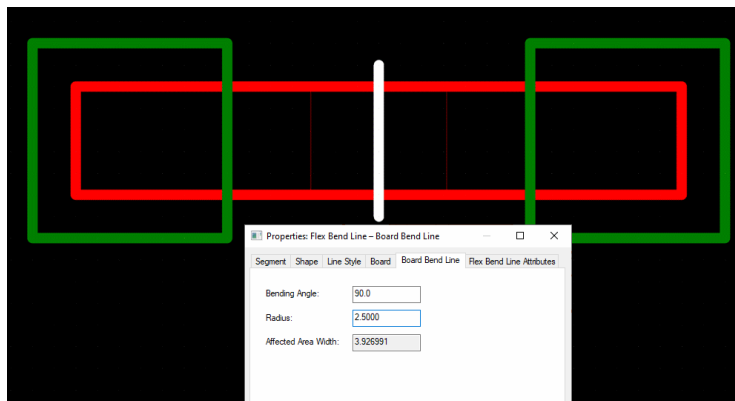

### 3D Settings for Flexi Board Folding

There is a **Flexi Board Folding** section on the **3D Settings Interaction** page accessed via the **3D Design** menu. This defines how the folding will behave and its use of animation. (See the section below for more details).

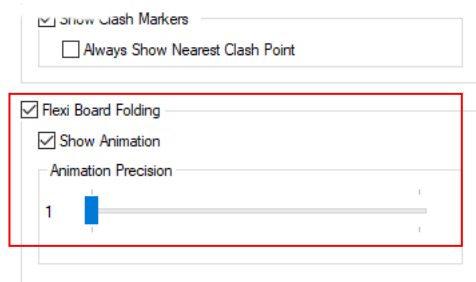

### Applying the Fold in the 3D Viewer

Once the boards are set up correctly in the PCB, you can enter the **3D Viewer**.

To perform the fold, use the **Fold Flexi Boards** option on the **3D Design** menu. Using this option when flexi boards are already folded will unfold them using the same animation options applied in **3D Settings**.

The **Fold Flexi Boards** option can be used alongside the **Fold Board** option.

When folding, if the bend radius is outside of boards, a **Folding Clash** error will be reported.

### Illegal Items

Some items are not allowed in bend regions. This will be shown in the **3D Viewer** with a **Bend Region Clash** label being shown and the offending objects highlighted in red. If there are clashes, that specific fold will not be performed, but all others will be. Items not allowed in bend regions include:

- Components

- Boards

- Other items may also not be allowed by your manufacturing process, such as Vias.

### Design Rules Checking

**Design Rules Checking** has a new category, **Flexi Bend Regions**, under the **Manufacturing** section. (see below under **Flex Bend Regions DRC** for more details).

## 3D Flexi Board Folding Settings

### 3D Settings Interaction Dialog

The **3D Settings Interaction** page has been reorganised and there is now a **Flexi Board Folding** section. Generating the shapes required for folding flexi boards is done when launching **3D Viewer**, which can take a long time. The **Flexi Board Folding** check box allows you to disable (or enable) flexi folding which will skip the shape generation and save time (which is useful if you want to generate the **3D Viewer** but not actually do any folding).

If disabled, you will not be able to fold. The shapes required to fold are calculated during the initial generation of the 3D view, which can take a long time. If it is not required for the user then they can disable it to save time.

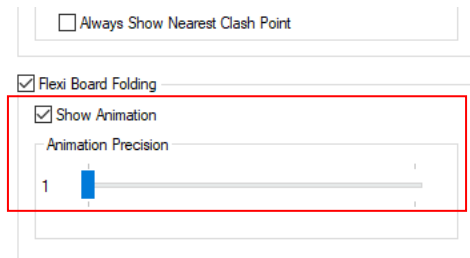

The **Show Animation** check box lets you toggle whether or not the folding of the flexi board should be animated or not. This is used in conjunction with the Animation Precision step slider and lets you fine tune how many steps should be in the animation (the more steps, the smoother the animation, but it will take longer to generate).

**Animation Precision** uses a slider that moves from 1-3. Animation Precision at level 1 will have the smallest load time but the animation will be less smooth and at 3 it will have the longest load time but smoothest animation.

### 3D Settings Settings Additional Settings – Flexi Bend Regions

A new check box has been added to the **Advanced Settings** section on the **3D Settings Settings** page. Enabling **Flex Bend Regions** will cause the regions to be shown in the **3D Viewer**, and disabling the check box will hide them.

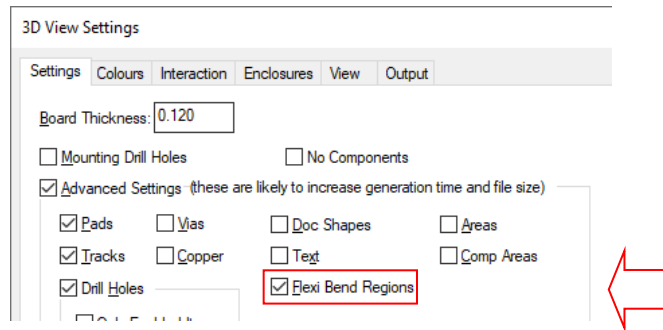

### Changes to Insert Board Origin

The original **Insert Board Origin** is now called **Insert Board 3D Origin**. This option have been added to the **3D Design** menu.

This option (using it's new name) is still available on the context menu when a board is selected.

This option is still used for annotating plain PCBs on top of each other (that is, non-flexi boards). If the board is a flexi, use the **Insert Flex Bend Line** option instead. The former is a simple quick method of transforming boards.

When using this option, you will only require **Board Names** and **Board Type** (to designate the static and moving portions of the design).

## Insert Flex Bend Line

There is a new **Insert Flex Bend Line** option. This is used when your design has flexi boards within it. It is not used when there are two 'normal' boards that which to be transposed, in this instance, you will use Insert Board 3D Origin.

The **Insert Flex Bend Line** option is available on the context menu when a board is selected.

The **Insert Flex Bend Line** option overrides **Insert Board 3D Origin** if there are placement conflicts. Board names are only used for the Insert Board 3D Origin option and are not required for Flexi boards.

### Using this option

You would only have one **Rigid Fixed** board in the design, all other boards move in relation to this one.

**Board** outlines in **Properties** needs to be type, **Flex** or **Rigid Moving** and on the correct span layer.

**Flex** denotes the actual flexi portion of the board, whereas, **Rigid Moving** indicates that this board will move.

To move the board, define it as **Flex Moving**:

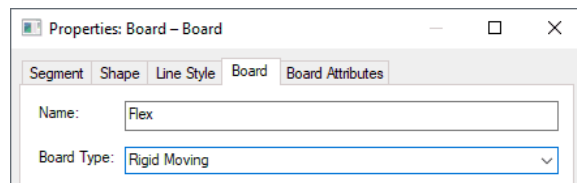

The **Layer Span** for the **Shape** will be your layer span already defined in the **Layer Span** page of your **Technology**.

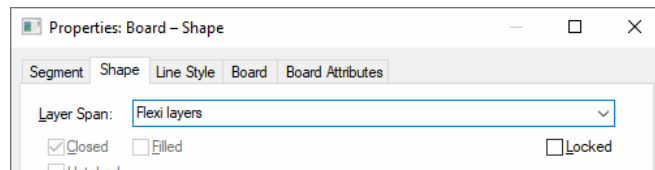

### Defining the Flex Bend Line

When using the **Insert Flex Bend Line** option (for a selected Board), it must span and reach outside of flex board outline. The line must pass the centreline but a warning is issued if it doesn't meet the criteria.

Self intersecting bend lines are also not allowed and can only intersect 2 area outlines. Multiple bend lines are allowed but care must be taken to ensure their Affected Areas do not overlap.

The image below shows an illegal bend line as it intersects more than two board outline shapes of the same board.

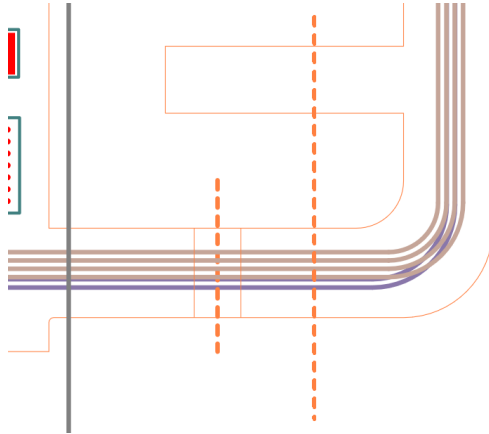

### Bend Line Properties

The **Bend Line Properties** dialog for a selected bend line enables you to define the folded boards' angle (**Bending Angle**) and the curve **Radius**.

Bending Angle:	<input type="text" value="90.0"/>
Radius:	<input type="text" value="2.0000"/>
Affected Area Width:	<input type="text" value="3.141593"/>

The **Bending Angle** will be final position as an angle relative to the fixed board.

The **Radius** of the bend, (direction + up – down).

The **Affected Area Width** is calculated from the Bending Angle and Radius, and is shown in the design. Bend lines know where the nearest Fixed board is and do not allow the Affected Area to be inside this fixed board. The Affected Area will be the **Flex Bend Region** once in the design.

### Flex Bend Line Bend Regions

Once defined, in the design, the flex bend lines show the region that will be affected when the bend is applied, this is shown as a translucent region (the same colour as the Bend Line).

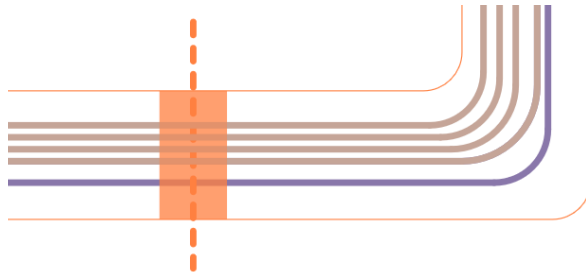



### Copy/paste Bend Lines

You can also copy and paste Bend Lines. As bend lines require a board to function correctly, you are unable to paste a copied bend line if you have nothing currently selected. If you have a bend line selected when pasting, it will copy the values of the bend angle and bend radius to the newly pasted bend line, and it will be linked to the same board that the currently selected bend line is linked to. If you have a board currently selected, pasting a bend line will link the new bend line to that board, but will not copy any angle or radius values.

### Bend Regions shown in the 3D Viewer

Flexi bend regions are visible in the **3D Viewer** as seen in the picture below in yellow. The bend region is shown as a wireframe outline of the region of the board that will be folded.

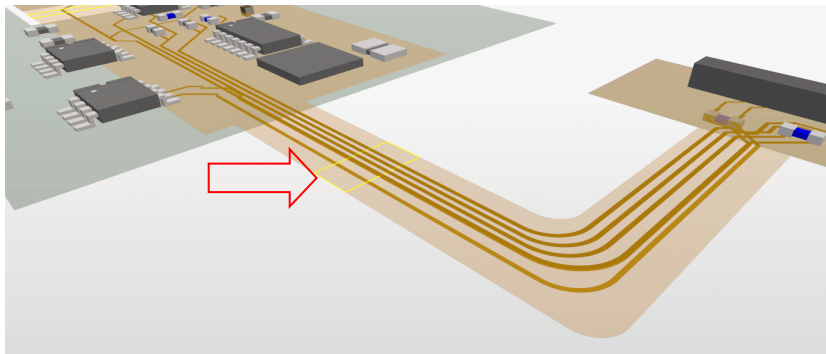

The colour is defaulted to yellow, but can be changed on the **3D Settings Colours** page, in the **Board** section, by changing the **Flexi Bend Regions** colour combo.

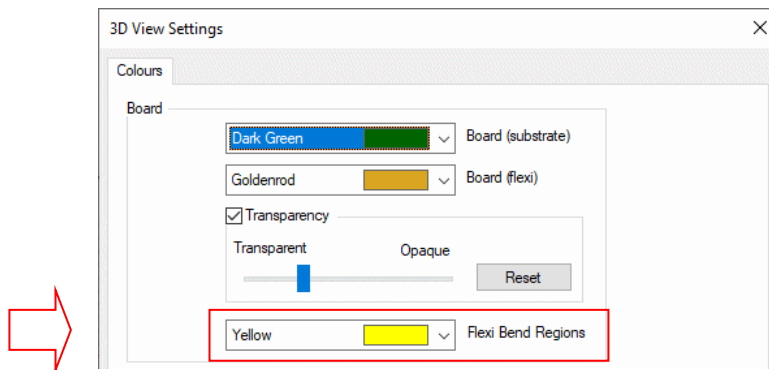

The bend regions are not output when using the **Output STEP file** and **Output STL** options but the fold status is (folded or unfolded).

### Comp/Via Keepout Areas in 3D Viewer

**Component** and **Via Keepout Areas** are can now be shown in the **3D Viewer**.

The area shape displayed in the **3D Viewer** will be a 2D shape wireframe if the area is on a single layer (and without a component height restriction), and if the area is on a span, the area shape will

cover that entire span. If the area has a component height restriction, then the area shape height will be altered to account for this.

Below is an example of two areas and a component. The closer area is on layer <Flexi1> with max comp height of 0.5mm, and the further area is on layer Flexi-span with max comp height of 1.2mm (the height of that component is 1.1mm).

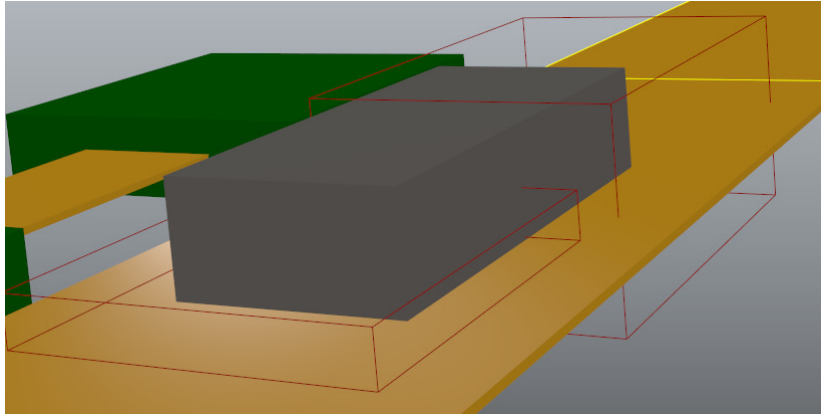

Areas can be enabled/disabled in **3D Settings** and the **Settings** page under **Additional Settings** section, by toggling the **Area** check box.

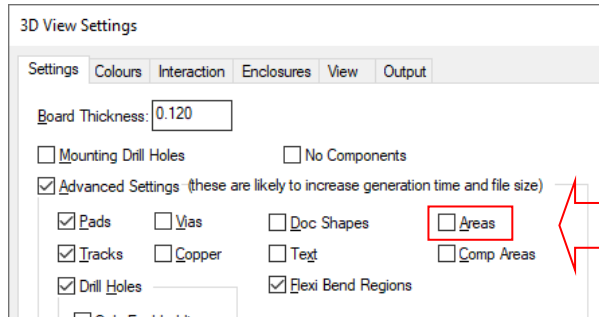

An **Area** colour selection has also been added to **3D Settings Colours** page, which has a default colour of **Dark Red**.

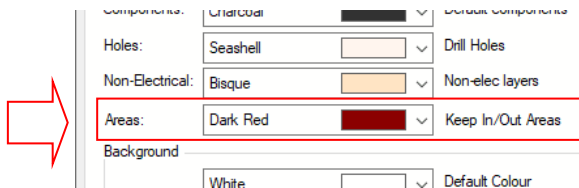

Areas are not output when using the **Output STEP** or **Output STL** file options.

## Flex Bend Regions DRC

### Flex Bend Regions DRC

A **Flex Bend Regions** check has been added to the **Manufacturing** section of **Design Rules Checking**. When run, if errors are found, this will report an error code **FB**. This uses the area that is recognised as the **Affected Area** calculated from the **Bend Line** and **Radius** and reported in **Board Bend Line Properties**.

Running this will check for anything that will cause issues with Flex Board Folding in the **3D Viewer**, and should be run before using the **3D Viewer**.

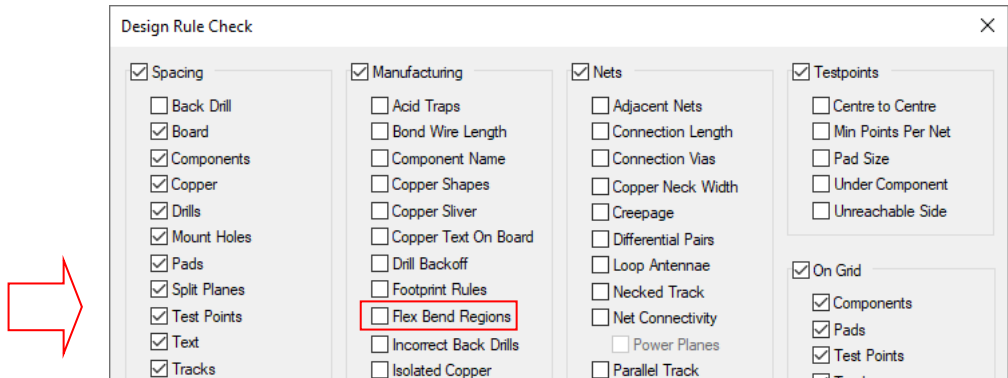

This DRC check looks for the following potential issues:

**Flex bend lines without a bend region.** This could report errors where the defined Angle or Radius is zero, or because the bend region is too large for the section of board where the bend line currently is. If this is the case when the 3D Viewer is launched, this bend will be ignored.

**Flex bend regions intersecting with other flex bend regions.** Two regions intersecting will cause one region to bend but not the other when in the 3D Viewer.

**Flex bend regions intersecting with boards.** If the region intersects with a board, then it will cause an illegal bend, and so will be ignored.

**Flexi board folding works by folding flexi boards and transforming Rigid Moving boards around a single Rigid Fixed board.** If another rigid fixed board exists in the collection of boards being folded, then it will cause unintended folding (as the fold direction is determined by its relative position in comparison to the fixed board). The check will look for multiple fixed boards in a collection of boards.

### Flex Bend Region Area Keep Out DRC

Flex Bend Regions are checked when using the **Component Keep Out** and **Via Keep Out** checks in DRC. This means that if **Components** or **Vias** are inside Flex Bend Regions, an error code will be shown (Cm-A for Components, V-A for Vias).

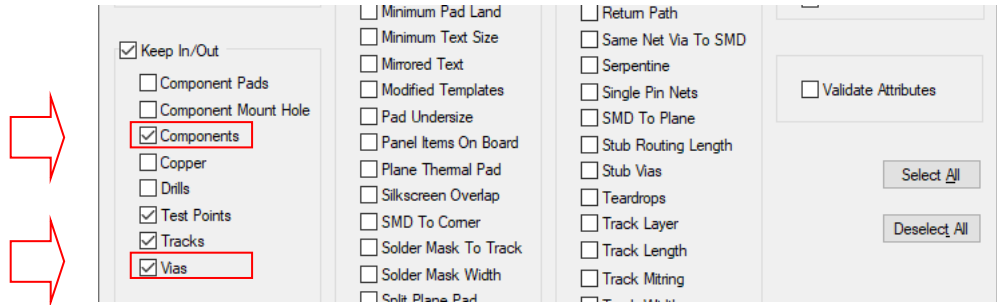

These errors are also flagged when using **Online DRC**, when dropping a Component or Via inside a bend region an error message will appear.

### True Folded Board Status used in STEP Output

Folded boards in their actual fold status (folded and unfolded) are now output when using the **Output STEP** option. This is the case for boards folded using the **Fold Boards** option on the **Tools** menu in the **3D Viewer**, and for folded flexi boards using the **Fold Flexi Boards** option.

### Changing STEP Colours No Longer Regenerated For 3D Viewer

When in the **3D Viewer**, changing colours and transparency on the **3D Settings Colours** page will no longer need to regenerate the entire 3D view.

This is not available when using **Exploded View**.

### Output STL File

The **Output STL** file export has been added to the PCB design **3D Design** menu. This will output the current PCB into STL format. This is an alternative format instead of STEP for use with MCAD systems that support it, such as SolidWorks. It is also one of the most common file formats for 3D printers. This capability allows you to 3D print the populated board as a single item. This could be useful for physical visualisation, mockup, and prototyping.

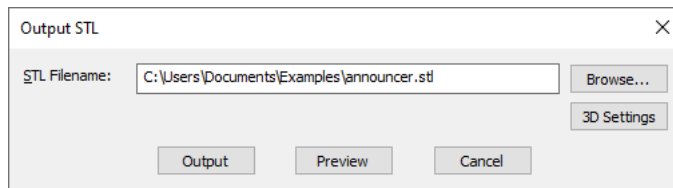

The STL format is a 3D output that only outputs a single shape, and so uses the **Single Entity Merge** functionality to regenerate and merge the entire PCB design into a single shape. Using the Single Entity Merge switch means the colour of the STL file is neutral and cannot be changed. The resultant file will be in the region of approximately 50% smaller than the file created when outputting to STEP.

The merged items are then output to the STL file, and then the **3D Viewer** will regenerate to show the non-merged items. If the single entity merge option is enabled when outputting STL, no regeneration is required.

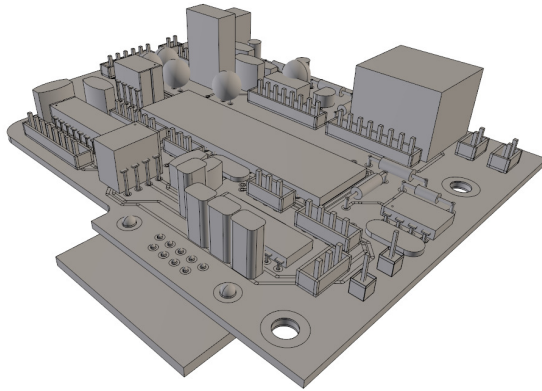

## Output As A Single Merged Entity

You can now opt to output STEP as a single entity using the **Single Entity Merge** check box on the **3D Settings, Output page**. This will also be available when running the **3D Viewer** inside Pulsonix.

Checking the **Single Entity Merge** check box merges the entire 3D data shapes and components into one single entity contained 'inside' an assembly so that it can be imported into other software as one shape.

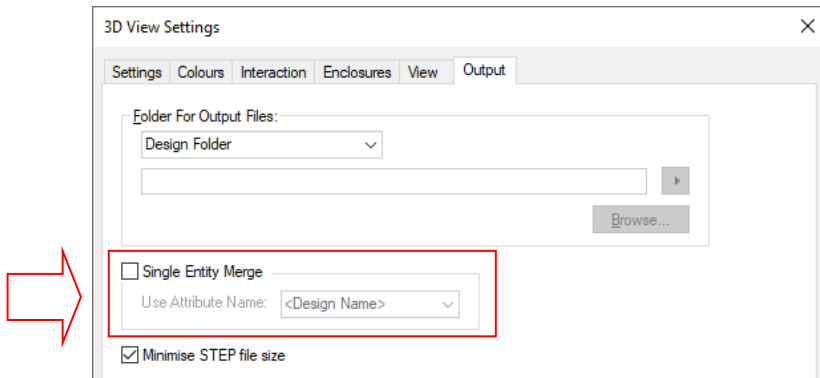

The major difference is that the 3D representation of the PCB shown in the **3D Viewer** now shows the merged shape, which can then be output with a reduced STEP file size. However, as the shape in the **3D Viewer** is a single entity, interactive options will no longer affect the shape, and all colours associated with the shape are removed. The removal of colour is a common feature also found in other 3D packages that can export single entity designs, such as FreeCAD.

By default, the <Design Name> is used for the internal entity but you can also specify your own attribute name. Use the **Use Attribute Name** box if you wish to specifically name the shape output to the STEP file. This could be the <Current Variant> attribute for example.

Using this feature can greatly reduce the loading time in SolidWorks.

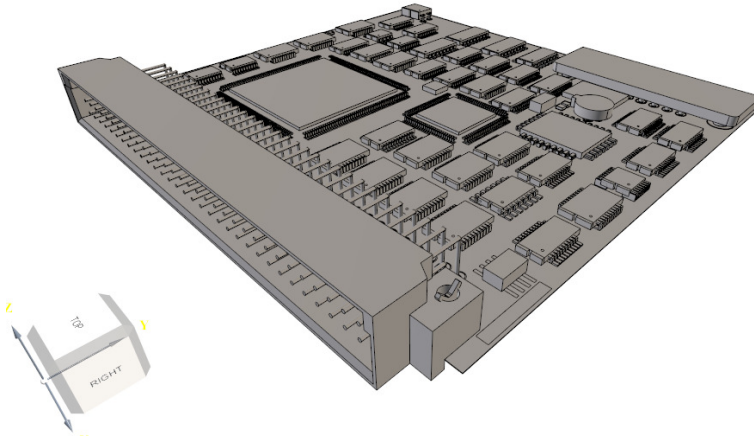

*This feature was back-fitted to V12.0*

### Updated 3D Viewer Functionality

Functionality has been updated in the 3D Viewer, the changes include:

#### Zooming

Zooming in/out using the mouse wheel now zooms towards the position of the cursor. You can still use the shortcuts **Z** and **U** or the **Zoom In** and **Zoom Out** options on the **View** menu to zoom in and out as before.

#### Rotation Axis

When performing camera actions such as rotating and panning, a small '+' will appear at the origin point of this camera transformation. This means you can visually see the point at which the camera is rotating around.

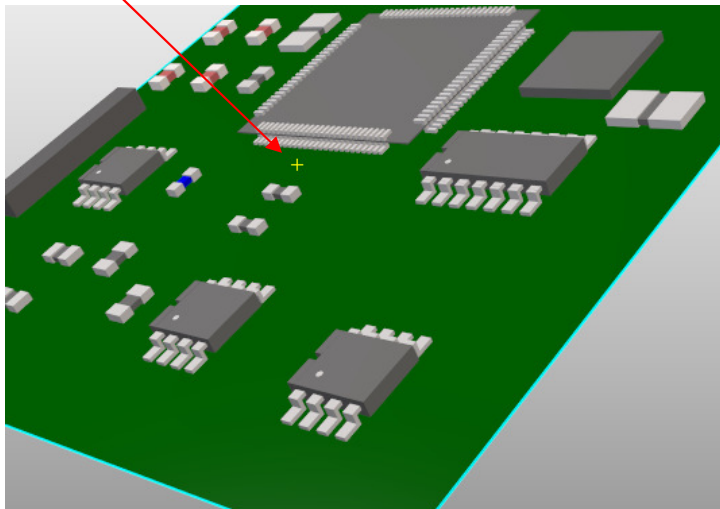

## Extended Design Rotation

As it has been, using the standard right click rotates in an orbit around the centre point of the design, (and now also indicated by the new rotation axis, see above). Now you can use Ctrl right click, or shift right click which rotates the view centred at your position (as if the camera is your head and you are looking around). This enables you extra precision within the positioning movement if you require a very specific view to be captures for an image for example.

## Use STEP Model as Enclosure

A new <STEP Enclosure> attribute has been added which can be added to a component.

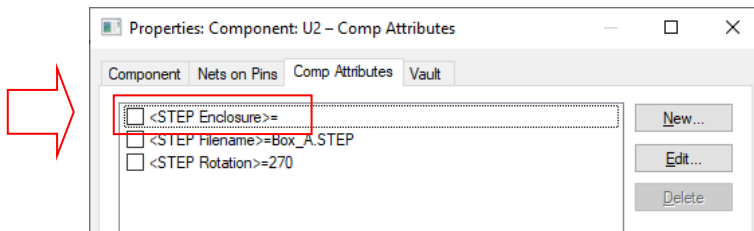

If a Component has this attribute (it doesn't need a value), the STEP model will be added as an enclosure in the 3D Viewer instead of being added as a Component/STEP model. This means that if enclosures are disabled in the 3D Viewer, these Components/STEP models won't be displayed.

When using this attribute, the enclosure colour and transparency will be used for these shapes as they are now considered Enclosures.

When viewing the **3D View Settings** dialog and **Enclosures** page, Components with the STEP Enclosure attribute assigned will be shown with the Component name next to each one in square brackets.

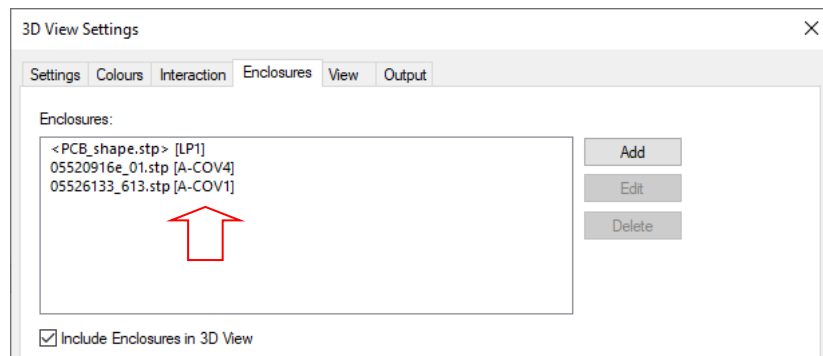

## Improved Performance for Position STEP Model Rotations

**Rotating** in the **Position STEP Model** dialog has been improved so that the view is no longer regenerated every time a new rotation is entered into one of the controls.

Inputting an X, Y or Z value into the controls will generate a new rotation transform, performing the rotation in Z first, then Y and finally X. Visually nothing will have changed, but there is a significant performance increase, especially on larger models.

### Interactive Rotating Changes in Position STEP Model

In the **footprint editor** and **Position STEP Model** option, changes have been made to the interactive rotating when updating the X, Y and Z controls (using the axis that appears when selecting the STEP model). These changes improve the visibility of the model in relation to its initial state (based on how it was created) and the footprint it is being positioned on. The new axis now looks like this. Each axis movement is coloured and is interactive. It can be selected and moved to adjust the position of the model in the preview. The relative coordinates are then reflected in the numerical values in the dialog.

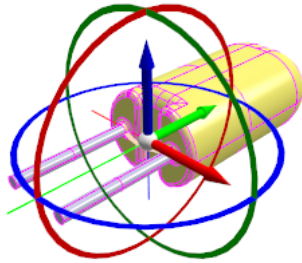

In summary, the changes made are:

- The axis has been moved from the centre of the STEP model to the point that the model is being rotated around.

- The axis itself now does not rotate when rotating the STEP model, keeping the X, Y and Z axes static.

- Using **Undo** after interactive rotation now updates the X, Y and Z controls.

- The trihedron axis is now static (it no longer rotates when rotating interactively).

### STEP Model Alignment and Snap by Centre

When using the **STEP Model Alignment** feature **Snap by Centre** option in **Design Settings**, the model can be automatically rotated by 90 degrees in the Z axis to better fit the footprint. If this happens, it causes any rotations in the X axis to look like they are being applied to the Y axis, and vice versa. The trihedron axis is now rotated to show this. This means that a rotation in the Y will rotate about the trihedron's Y axis, which would be the world space's X axis. This option has been amended because previously, it wasn't obvious in this instance that the model had been rotated.

This image shows the model position using **Snap By Origin** before any positional or rotational corrections have been applied:



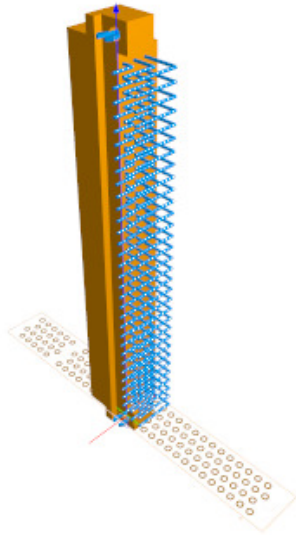

This image shows the model position using **Snap By Centre** using the same model. You can see that the model has been rotated by 90 degrees in the Z axis:

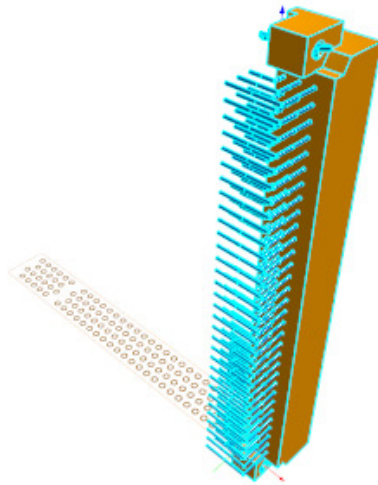

### New Trihedron Axis View Cube

In the **3D Viewer** and **Position STEP Model Preview**, the trihedron axis in the lower left corner has been replaced with a **View Cube** (the cube also retains the trihedron axis arrows).

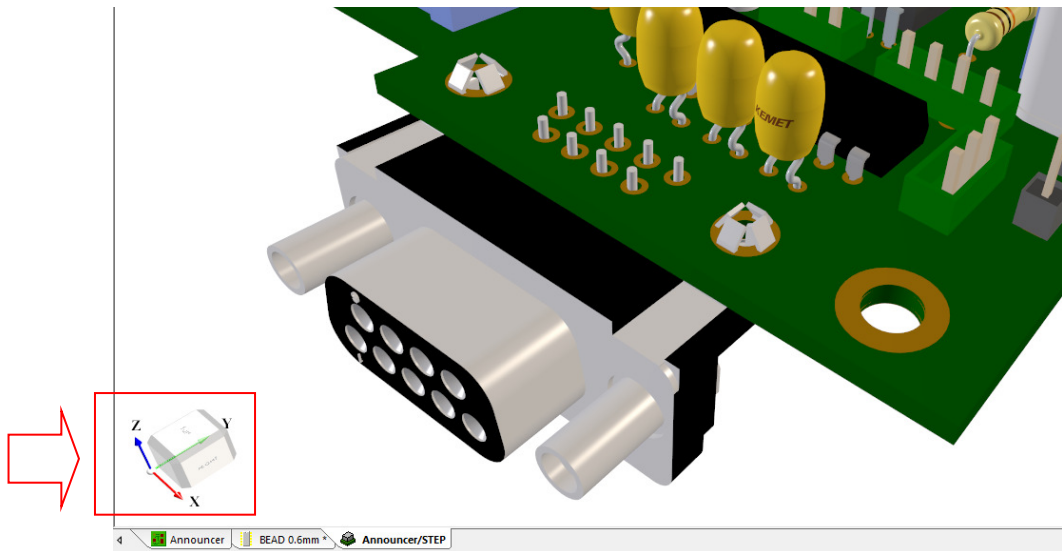

This is also available in the **Position STEP Model** preview:

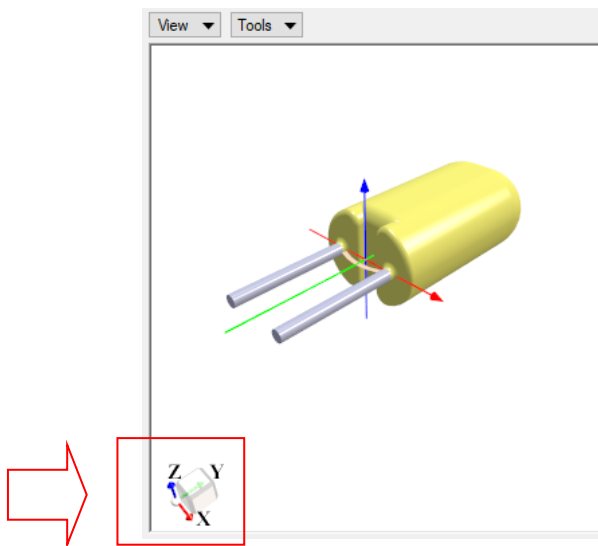

The cube will rotate as the camera is rotated, and clicking on a face, edge or vertex of the cube will automatically rotate the camera to that orientation. Double clicking on the cube will spin the camera so that the board is the correct orientation.

The display of the cube is switchable in the **3D Settings** dialog under the **View** tab. From this page, you can also define the **Position** of the cube in the preview window.

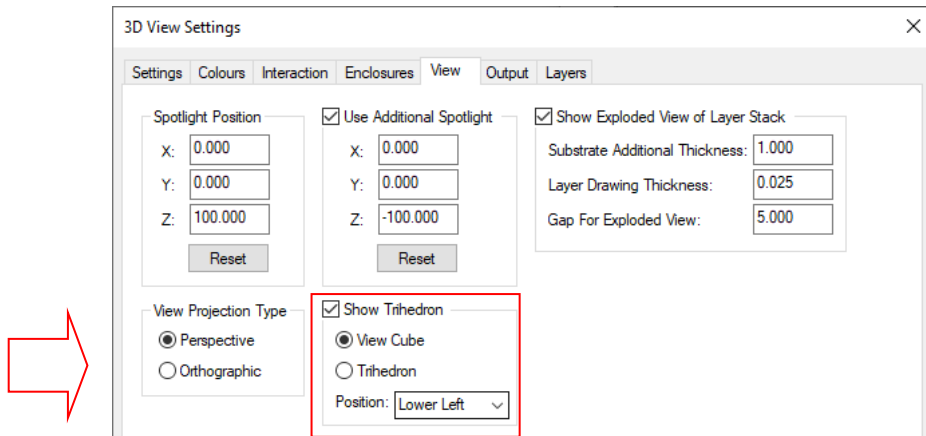

## Additional Spotlight

In the **3D Settings** and **View** page, there is a new **Use Additional Spotlight** option that allows adding and defining of a second spotlight. The position of this spotlight is defaulted to  $\{0,0,-100\}$  and will light up the bottom of the board, but can be moved using the X, Y and Z controls. Using the **Reset** button will reset the position back to  $\{0,0,-100\}$ .

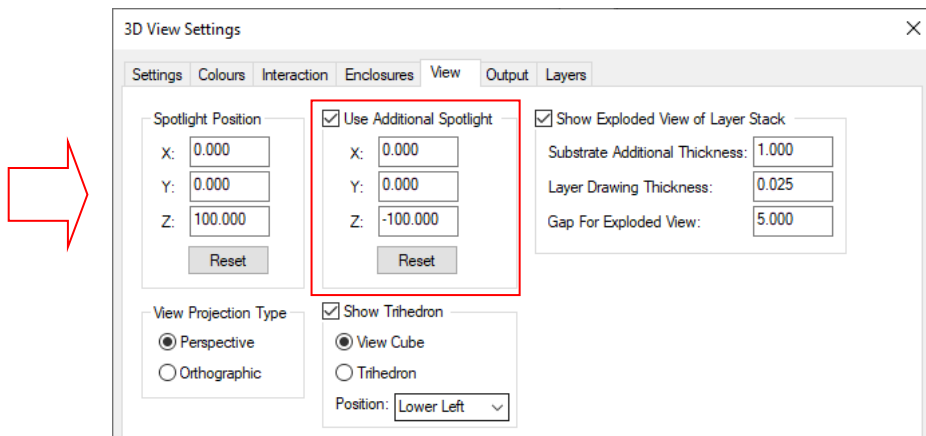

### 3D Settings – Show Drill Holes for Enabled Items Only

There is a new check box on **3D Settings** on the **Settings** page named **Only Enabled Items**. This option will allow you to only show drill holes for items that are enabled in the **Advanced** section.

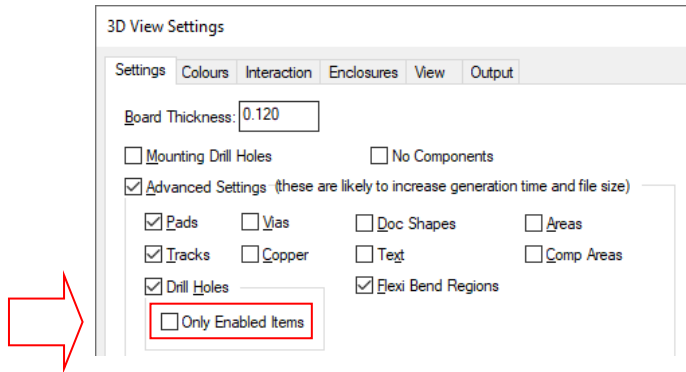

For example, if you have this option enabled, and you have pads enabled but vias disabled, then drill holes will be created in the board shape for pads but not for vias. If you disable this new option then all drill holes will be added to the board, as before.

*This was backfitted to V12.0.*

### Footprint Moves with Component

In the **3D Viewer**, after moving a Component its footprint will also be moved in the Preview. Note, the drill holes will not move without a full redraw.

### Find Bar Changes

#### Find Unpoured Templates

You can now find **unpoured** templates from the **Find** bar using a special attribute filter.

Once **Template** has been chosen as the find item:

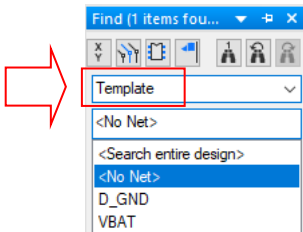

Set the **Filter** to **Attribute** where a new special attribute of **<Unpoured Template>** is available in the selection list:

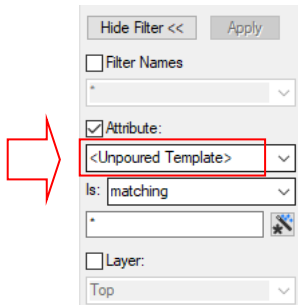

You can also set the criteria using the **Is:** statement and **Layer:**.

The results will be displayed for net named templates and templates without a name (shown as <No Net>). Unnamed templates will only show one entry for all templates but you can toggle through them using the Next and Back arrows at the top of the dialog.

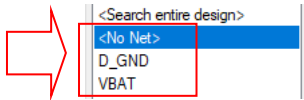

*This feature was back-fitted to V12.0.*

## Insert Text – Select Text Style

On the **Insert Text** dialog there is now an option to select the **Text Style** before adding text to the design. This is not available for text callouts.

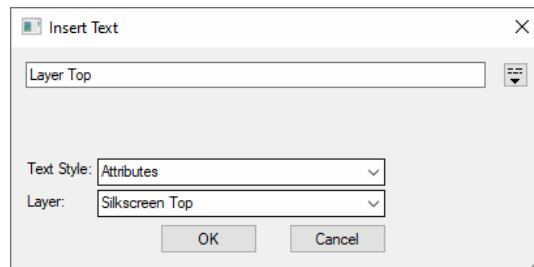

## Highlight List from Design Selection

There is a new option on the **Find** context menu called **Highlight List from Design Selection**. Once selected, this will highlight items in the **Find** Bar list in context of the selection based on what you select in the design.

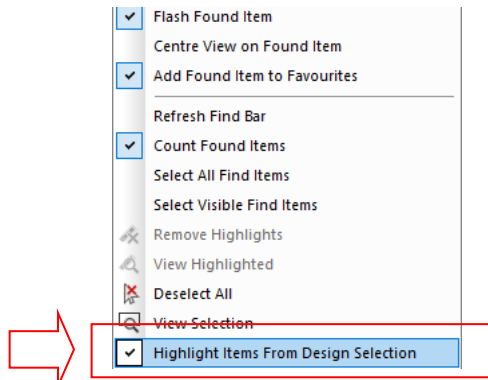

A couple of practical examples of where this may be used are if you were to select some capacitors in the design, then in the **Find** bar, have the find set to **Parts**. This means that the Find bar would now show you all the Part types used for the selected capacitors. This would be good for showing different Parts where you might expect to be using the same Parts.

Another example might be where the **Find** bar is set to **Net** and you select a Component in the design. The find bar will now show you all the net names attached to that Component.

### Insert Component - Find a Part by Schematic Symbol Name

From the **Insert Component** dialog, **Find** option, you can now match by the **schematic symbol name** using the **Sym** header.

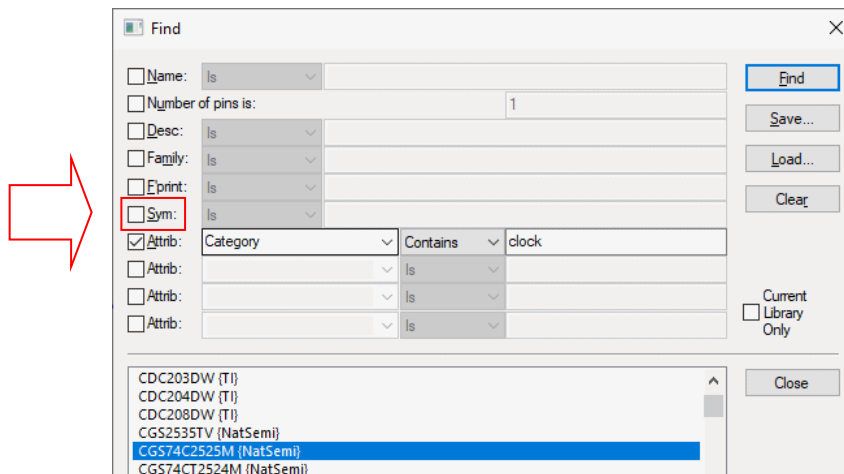

### Parts Library

#### Splitters added to Part Editor

Splitters have been added to Part Editor. These will enable you to control the size of the preview windows.

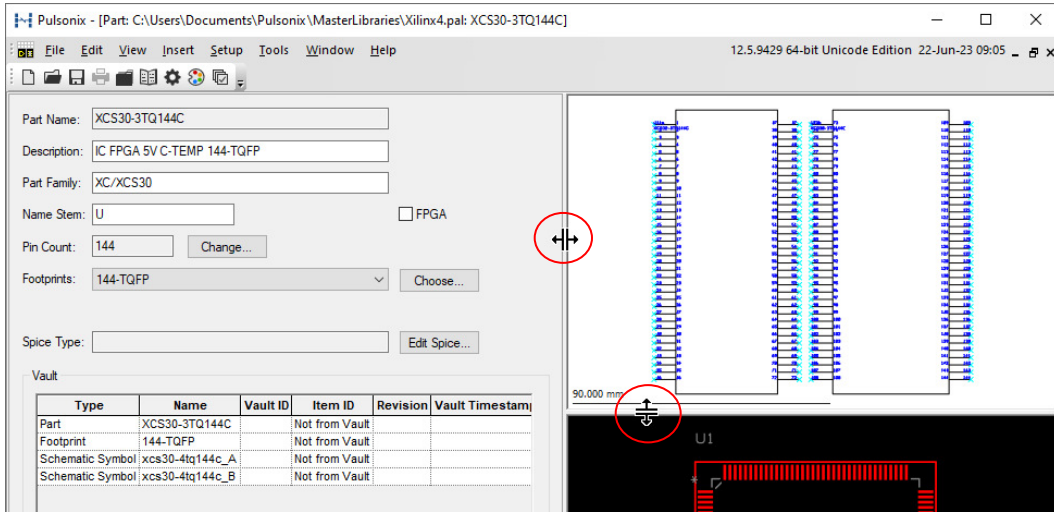

### Edit Symbol available from Preview window

From the **Parts** tab of the **Library Manager**, on each of the two previews (SCM Symbol and PCB Footprint), if you right click over the symbol, from the context menu, you can select **Edit Symbol / Footprint In Library**. If the Part has multiple Schematic Symbols, they will each open in a different tab.

From the context menu in the preview, you can also reset the view of the preview windows using the **View Extents** option.

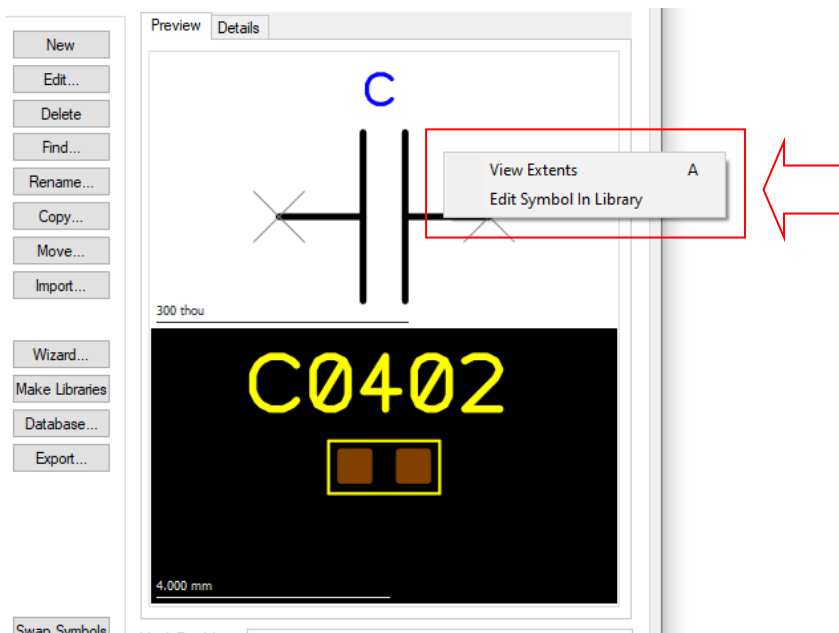

### Connector Part – Different Symbol Name on Pins

When editing a **Connector Part** in the **Parts Library (Pins page)**, you now have an additional column named **Symbol**.

Normally, the Symbol name will be the same for every connector pin on the Part. However, you can now change the symbol to make one or more pins different, for example, Pin 1.

Footprint Pin	Pin Name	Net Name	Pin Type	Pin Network	Pin Swap	Symbol
1	1		<Undefined>	<None>	0	1P
2	2		<Undefined>	<None>	0	1P
3	3		<Undefined>	<None>	0	1P
4	4		<Undefined>	<None>	0	1P
5	5		<Undefined>	<None>	0	1P
6	6		<Undefined>	<None>	0	1P
7	7		<Undefined>	<None>	0	1P
8	8		<Undefined>	<None>	0	1P
9	9		<Undefined>	<None>	0	1P

If you select the Symbol name for the pin you wish to change, you are now presented with the **Change Symbol** button.

Pin Network	Pin Swap	Symbol
None>	0	1P
None>	0	1P
None>	0	Change Symbol
None>	0	1P
None>	0	1P
None>	0	1P
None>	0	1P
None>	0	1P
None>	0	1P
None>	0	1P

This displays the **Change Symbol Name** dialog which enables you to select the new symbol name.

Pin Network	Pin Swap	Symbol
None>	0	1J
None>	0	1P
None>	0	1P
None>	0	1P
None>	0	1P
None>	0	1P
None>	0	1P
None>	0	1P
None>	0	1P

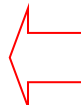

Once used in the design, changing Pin 1 will look like this:





## New Pin Types for Ancillary Pads and Mounting Holes

You can now define **Pin Types** of **Ancillary Pad** or **Mounting Hole** for use within a Part/Component.

When either of these new Pin Types are assign to Pins, they do not contribute to the Part Pin Count.

These may be useful for defining a pad on a footprint (an Ancillary Pad) that is a ‘belly’ pad for example, used for a thermal connection which would not be a normal Pad or a Mounting Hole. You may also use this new Pin Type for defining a Schematic pin on a Part that will be connected to with a Net and which appears on your Schematic design.

**Ancillary Pad** defines a pad which does not contribute to the overall Part Pin Count. In all other respects it is a normal Part Pin. It has a pin name, can appear on a schematic symbol, and requires a pad in the footprint. As mentioned above, this might be used to define a belly pad for example, used on a surface mount device with a thermal connection.

**Mounting Hole** defines a pad which does not contribute to the overall Part Pin Count.

Also, in a PCB design, it is treated like a Mounting Hole for Rule checking purposes. In all other respects it is a normal Part Pin. It has a Pin Name, can appear on a Schematic Symbol, and requires a pad in the footprint, (the footprint will therefore have more pads than the Part Pin Count). This means it can be shown on the Schematic Symbol and design also, and be connected to with a Net Name.

### Schematic Pin Types

When editing a **Part** in the **Parts Library** (**Pins** page), you now have two new **Pin Types** available: **Mounting Hole** or **Ancillary Pad**.

	Name	Type	Allow on Block Port
Y	Output		<input checked="" type="checkbox"/>
Y	Input		<input checked="" type="checkbox"/>
	Bi-Directional		<input type="checkbox"/>
	Open Collector		<input type="checkbox"/>
	Or-Tieable		<input type="checkbox"/>
	Tri-State		<input type="checkbox"/>
	Terminator		<input type="checkbox"/>
Y	Power	Power	<input type="checkbox"/>
Y	Ground	Ground	<input type="checkbox"/>
	Open Emitter		<input type="checkbox"/>
Y	No Connect	No Connect	<input type="checkbox"/>
	Passive		<input type="checkbox"/>
	Pcb Connect	Pcb Connect	<input type="checkbox"/>
	Mounting Hole	Mounting Hole	<input type="checkbox"/>
	Ancillary Pad	Ancillary Pad	<input type="checkbox"/>

Only Show Used Entries

### Using this Pin Type

Once the Pin Types are defined, they can be assigned to a pin in the **Part Editor**.

Footprint Pin	Pin Name	Net Name	Pin Type	Pin Network
1	1		No Connect	<None>
2	2	GND	Ground	<None>
3	3		Input	<None>
4	4	GND	Ground	<None>
5	5		No Connect	<None>
6	6		No Connect	<None>
7	7		No Connect	<None>
8	8		No Connect	<None>
9	9		No Connect	<None>
10	10		No Connect	<None>
11	11		No Connect	<None>
12	12		No Connect	<None>
13	13		No Connect	<None>
14	14		No Connect	<None>
15	15	GND	Ground	<None>
16	16		Output	<None>
17	17	GND	Ground	<None>
18	18		No Connect	<None>
19	19	Vdd3	Power	<None>
20	20		No Connect	<None>
21	21	Vdd2	Power	<None>
22	22		No Connect	<None>
23	23	Vdd1	Power	<None>
24	24		No Connect	<None>
25	25	GND	Ancillary Pad	<None>

The net name can be assigned optionally too as well as the Pin Type.

### Pad Numbers on a Part

When using the special **Pin Types** of **Ancillary Pin** or **Mounting Hole**, the pad number reported will be different to that defined on the footprint. In this situation, the **Pin Count** changes and the dialog is updated.

Part Name: HMC519LC4TR-2  
 Description: IC AMP VSAT 18GHZ-31GHZ 24CSMT  
 Part Family: HMC519LC4TR LNA  
 Name Stem: U  FPGA  
**Pad Count: 25** Change... Part Pin Count: 24  
 Footprints: QFN50P400X400X102-25N-2 Choose...

The **Pad Count** changes to reflect the actual number of pads defined. An additional **Part Pin Count** now displays the count, excluding any pins marked as one of these special types.

## Pin Types on Pin Properties

When the Part is used in the design with one of these pins defined, Mounting Hole, in the example below, the **Pin Type Properties** shows its Pin Type as Mounting Hole.

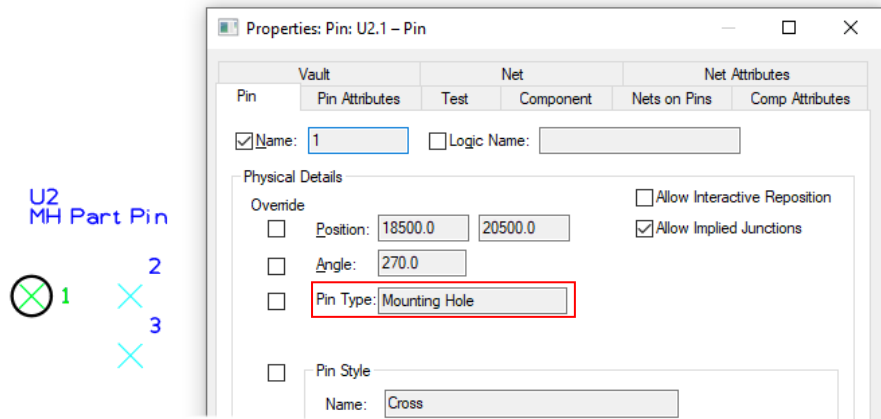

## Reload From Library - Match Gates by Pin Names in Schematics

There is a new option when using **Reload From Library** in a Schematic design called **Match gates by pin names**.

This will not normally be used but is available if you have imported a design using one of our import filters, such as Allegro, but the gates have been created in a different order from the library.

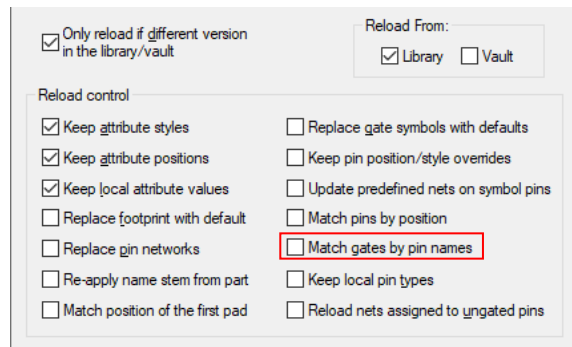

This option should only be used if you know you have multi-gate parts in the library where the gates are in a different order from the part in schematic design. For example, gate “a” in the design is pins 1 and 2 and gate “c” in the library is pins 1 & 2. The reload will swap the gate modifiers so that pin 1 is still connected to the same net.

*This was backfitted to V12.0.*

## Check for a Single Signal Refs in ERC in Schematics

When using the **Unfinished Nets** check in **Electrical Rules Check**, it now checks for a **single Signal References**. This means it will check for a second Signal Reference to join to and report an error if there is only one Signal Reference on that net.

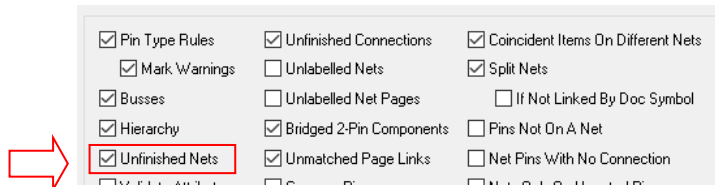

## Unmatched Signal Refs in ERC in Schematics

**Electrical Rules Check** has an additional option to find **Unmatched Signal Refs**. This was previously added as part of the Unfinished nets check, but has now been split into a separate option.

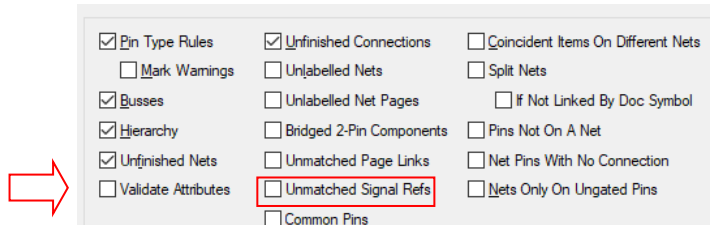

## Insert Connector Pin - Copy Previous Pin option

The **Insert Connector Pin** feature now has an option on the dialog to **Copy Previous Pin**.

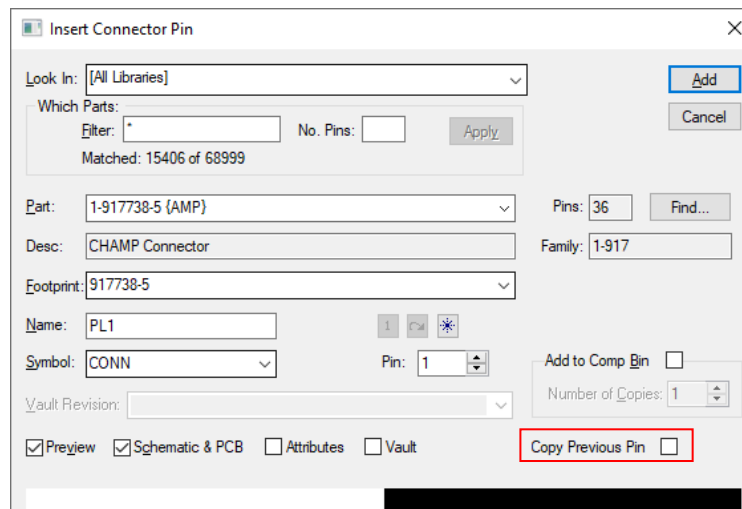

When selected, this copies the orientation and position of attributes from the previous pin on the current Component.

## Change Mounting Hole to Pad

You can now convert a **Mounting Hole** to a **Pad**. This will mainly be used in **footprint editing** but can be used in the PCB Design editor.

Use this by selecting the **Mounting Hole** and from the context menu, selecting the **Mounting Hole to Pad** option:

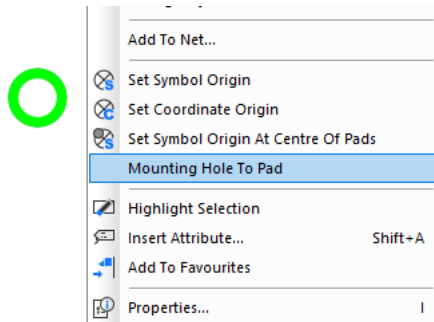

When using this in the footprint editor, the pad will take on the next Pad number in the sequence.

The pad will still use the same Pad Style but will now be a 'Pad' not a Mounting Hole. If the pad (as a Mounting hole) used Naming Rules, these rules will still be applied.

## Change a Normal Part to a Connector

You can now change a normal Part to a Connector. From within the **Part Editor**, select **Change Part Type** from the **Edit** menu.

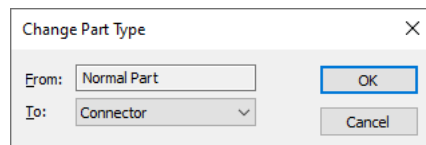

Once selected, this option will remove the **Schematic Symbol(s)**, remove the **Gate** tab and change the **Part Type** to a **Connector**.

## Inspector Bar Changes

### Change Group Order dialog improvements

The **Change Group Order** dialog has been changed to use a grid instead of a check-box list for displaying group information.

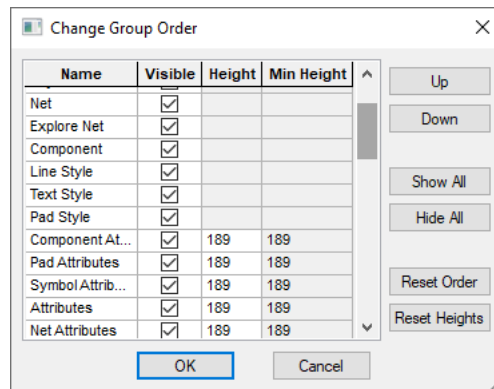

The grid contains four columns: **Name**, **Visible** (whether group is shown in the Inspector Bar), **Height** (the height that dialog-based groups should use, for example, Attributes group), and **Min Height** (the minimum height that the group can be resized to).

Not all Group Name Heights can be edited, but of the ones that can be, multiple group **Visible** and **Height** values can be changed at the same time. Do this by selecting a range and using the **Apply Height To Selected Cells** option from the context menu to apply a row value to the rest of the rows in the range.

Individual rows or a contiguous range of rows can be selected to allow multiple groups positions to be changed at the same time using the **Up** and **Down** buttons.

A **Reset Order** button has been added, this allows the group order to be reset to the default values.

A **Reset Heights** button has been added for a quicker way of resetting all group heights to the minimum (default) value.

#### Dragging to Create a Group Order

Dragging a selected row or range of rows using the mouse to another position in the grid can be used to change the group order quickly.

#### Pre-selection of a Group Row

Opening the Change Group Order dialog from the context menu after right clicking inside a group in the Inspector Bar will pre-select that group row in the grid to help locate it faster.

#### Persistent Group Heights

Group heights are stored in the registry so changes will persist between sessions.

## Block Groups in PCB Designs

When a **block group** is created in the PCB design through either the **Translate to PCB** or **Synchronise Design** options, the group name will now include the block name in square brackets. For example “B1\_ [CharacterLeds]”.

This can be viewed in the PCB design within, **Component Properties**, **Inspector Bar** and **Find** etc.

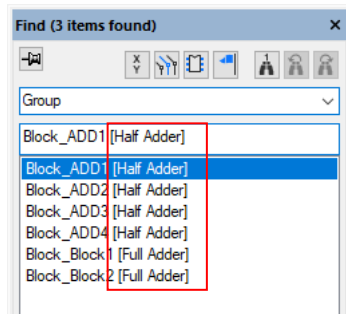

Like before, these groups are only created for a block instance if the **Create PCB Group** check box is checked in **Block Properties**.

When running **Synchronise Designs**, the report will show you this additional information to be added to the PCB design.

### What to do in V12.5 to use this feature

If you are using these groups in a design that was created in a version previous to V12.5, then be aware, you will now need to perform a **Synchronise Designs** to update the PCB design to change these group names to show the additional information.

If you don't update the PCB, the integrity will still be correct and match the Schematic but you will not see this additional Block Group information.

## Execute Hyperlink in Attributes grid

In the Attributes group grids, hyperlink enabled attributes can now be executed by right clicking on the attribute value column and selecting 'Execute Hyperlink' on the context menu. As a visual indicator that an attribute value is a hyperlink the text will appear underlined and in a blue *link* colour.

Name	Value	Visible	Source
<Hyperlink>	<a href="https://www.xilinx.com">https://www.xilinx.com</a>	<input type="checkbox"/>	
Category	FPGA/CoolRunner	<input type="checkbox"/>	Part
Mfr	Xilinx	<input type="checkbox"/>	Part

## Component Bin Changes

### Show Pre-defined nets on Single Pin Items in the Bin

If a Component in the Bin has a single pin or pad then it will show the **Net Name** next to the pin name if it has one. Such as a multi-pin connector in Schematics or a testpoint in PCB.

Once in the Bin, the pre-defined Net Name (but no actual connected net) will be shown prefixed with [predef: *NetName*].

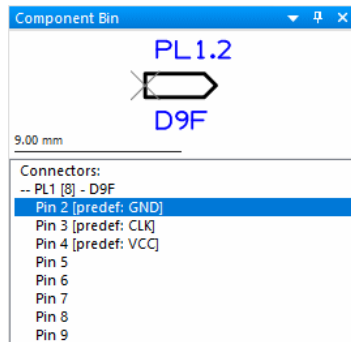

### Highlight Components on Marked Net in Bin

If you mark a net (using **Mark Net**) in the design, any components in the bin also attached to that net will be highlighted with a small rectangle on the left of the item in the mark net colour.

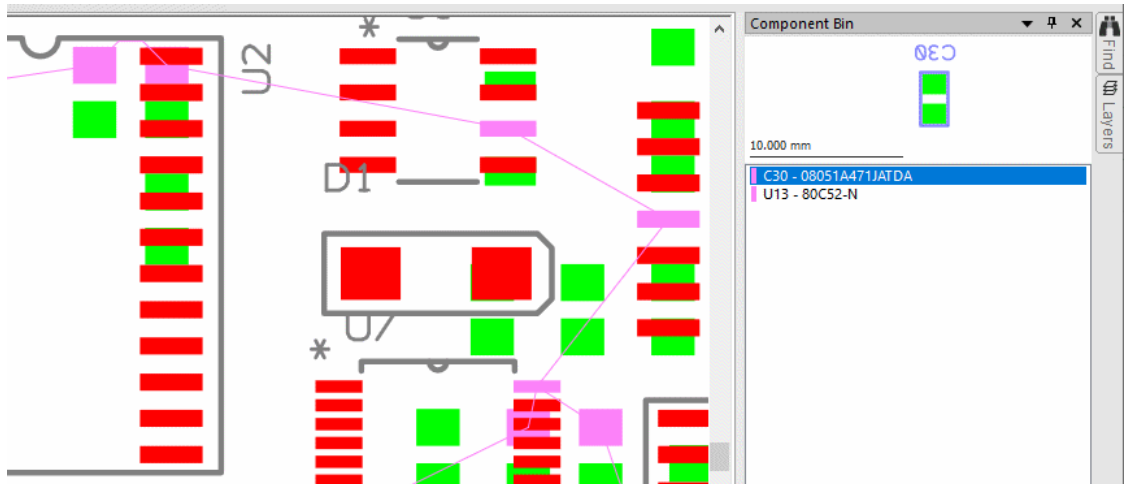



## Bin Filtering

The Component Bin now has a **Filter** panel. This allows you to just show the components you are interested in at a particular time. You can filter by Name, or Component Attribute.

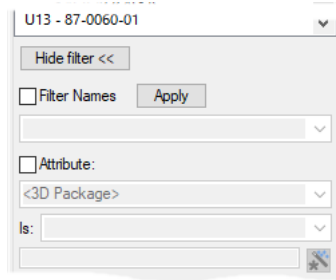

## Bin Sorting

The Component Bin now has a **Sort Order** panel. This allows you to set up a sort order and set a list of attributes to sort the bin by. This is a persistent order that is shared between designs.

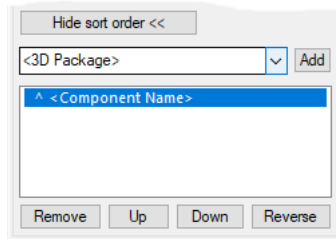

## Drag Out of Bin Ordering

When you drag multiple components out of the Component Bin, they are arranged in a horizontal line of columns (or a vertical line of rows) of Components. The columns are grouped by component type, and they appear in the order that they appear in the component bin.

New options for sorting and placing items has been added to the context menu.

You can use **Sort by '<Component Name>' in reverse order** to toggle the sorting within the component Bin. Previously, this was named **Toggle Bin Sort Order**.

To adjust the maximum width of the dragged rows (or columns in horizontal mode), right click on the Component Bin and then choose **Set Drag Out Row Width** from the context menu. Type a number into the dialog that appears to set the maximum row width (or respective column height).

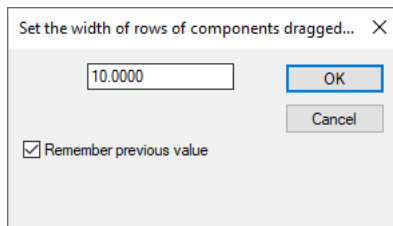

## Bus Properties – Report button

In Schematics, for **Properties** of a **Bus**, on the **Bus** tab, there is now a **Report** button. This lists the name of the **Bus**, and each **net** attached to it.

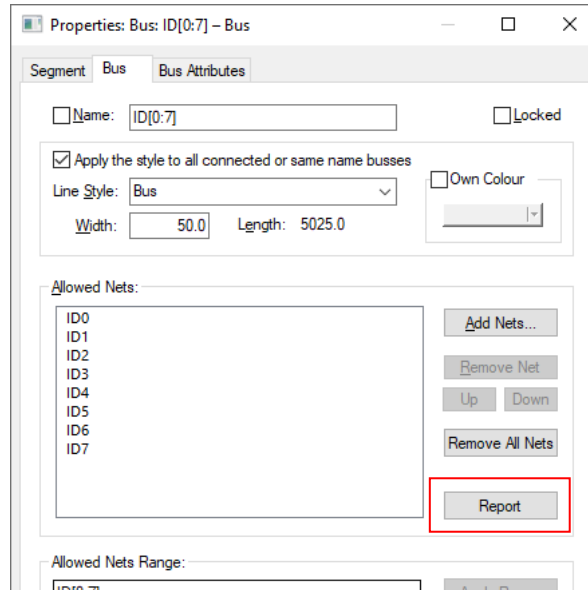

A report will look like something the example below:

```
Bus ID[0:7]333: ID[0:7]
Net Count: 8

1: ID0
2: ID1
3: ID2
4: ID3
5: ID4
6: ID5
7: ID6
8: ID7
```

## Rename Sub-net in PCB using Change Net

You can now rename a sub net in PCB when running in safe mode.

This feature is useful for where a Differential Pair of tracks, for example, have been partially routed in and their path is as required but the end pins need to be swapped.

However, the track path must not contain any additional pads and the tracks must not be routed at either ends. Differential Paired tracks with spurs (tracks plus vias) are acceptable though but the whole sub-net and spur must be selected.

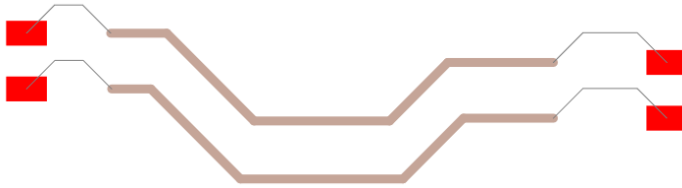

To use this feature, select the first track segment (or track path using Shift-Select).

Right click and choose **Change Net** from the context menu:

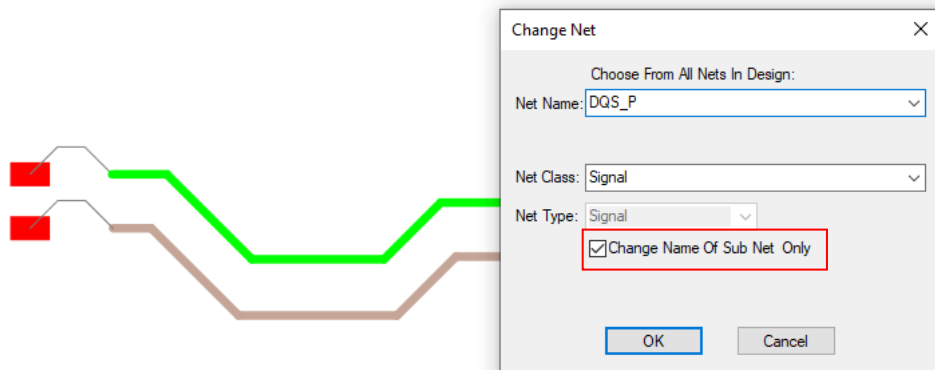

You are able to select the **Change Name Of Sub Net Only** option when the track path follows the rules.

You must do this on both track paths to swap, during which, it will temporarily join the two nets. Once both have been swapped, **Optimise** Nets will reorganise the connections and now display them as swapped.



### Auto-Rename - change a Prefix or Suffix

**Auto Rename** in both the Schematic and PCB design editors now allows you to add, remove or change a **prefix** or **suffix**.

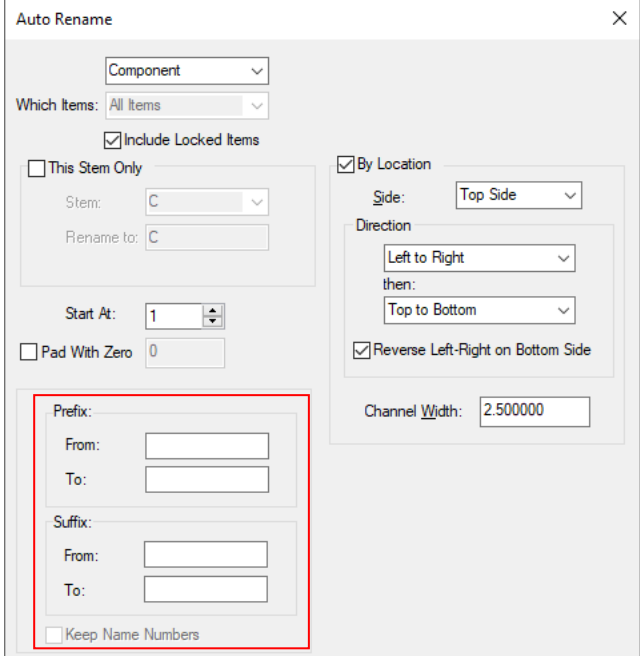

The screenshot shows the 'Auto Rename' dialog box. It has several sections: 'Component' (dropdown), 'Which Items' (dropdown), 'Include Locked Items' (checkbox), 'This Stem Only' (checkbox), 'Stem' (dropdown), 'Rename to' (text field), 'Start At' (spin box), 'Pad With Zero' (checkbox), 'By Location' (checkbox), 'Side' (dropdown), 'Direction' (dropdown), 'then:' (dropdown), 'Reverse Left-Right on Bottom Side' (checkbox), 'Channel Width' (text field), 'Prefix' (From/To text fields), 'Suffix' (From/To text fields), and 'Keep Name Numbers' (checkbox). A red box highlights the 'Prefix' and 'Suffix' sections, and a red arrow points to it from the left.

You can specify a Prefix or Suffix and you can change these strings *From* the specified value *To* a different one.

For example, 'U1\_ADD1' with Suffix *from* '\_ADD1' *to* '\_ADD2' would give 'U1\_ADD2'.

When enabled, the **Keep Same Numbers** switch means only the Prefix and Suffix will be renamed and all other names and formatting will be preserved.

*This was backfitted to V12.0.*

### Changes to Edit and Add Wire Functionality

Double clicking on a wire now allows you to edit it so that you can add multiple segments (with Mitres and Curves). This works the same as edit shape and can be used for editing a wire to create a shape. Previously, only a single segment wire was available; now the wire can be shaped to more accurately represent a physical wire that is placed on the manufactured PCB.

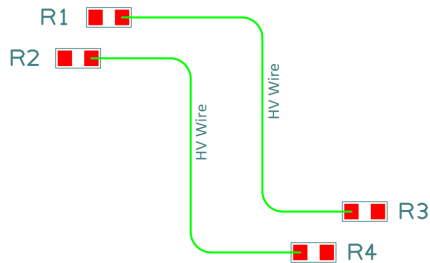

There are now new arc angle options in **Select Mode** (when you have a wire segment selected) and on the **Add Wire** context menus to change the angle of the lines' arc.

Once the segments have been added, there are additional options on the context menu when a Wire corner is selected:

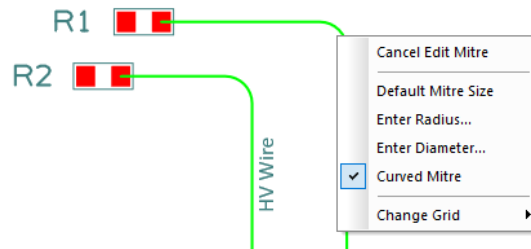

## Changes to Apply Vias option

The **Apply Vias** options on the **Utilities** menu has been renamed to **Apply Vias/Pads** to reflect the expanded functionality where it can now include **Pads**.

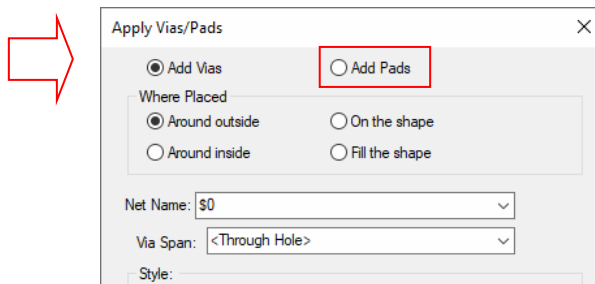

When switching to **Add Pads**, the dialog changes, with **Net Name** and **Vis Span** being swapped for the pad **Layer** selection. Pads can only be placed on a named layer and not with a Through-hole selection.

Pads added will be Free Pads on a single electrical layer and will not be on a net, this is useful for creating a thieving pattern, for example. These options also work in a footprint design, where Component Vias will be added (you cannot add free pads to a footprint).

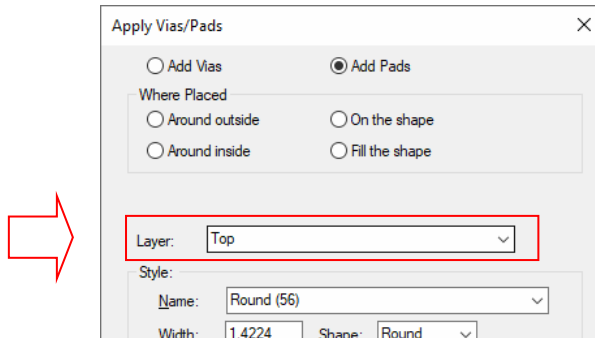

### Wire Defaults – Line Angle

Wire Defaults in **Technology, Design Settings, Defaults** and **Wire** now has a new **Line Angle** setting. This lets you set the default arc angle a wire will have when you add it.

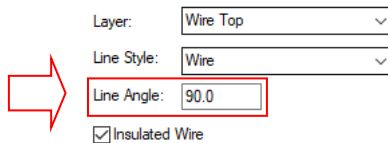

### Bitmap Scaling Changes

#### Large Bitmap Scaling

Large bitmaps will now be scaled down during import to a size relative to the current zoom level on the design.

#### Bitmap Scaling From the Context Menu

Bitmaps can also be scaled from the context menu during the initial placement stage.

#### Preserve Attached Segments during edge dragging

Scaling a bitmap by dragging the edges now uses **Preserve Attached Segments** when enabled.

#### Bitmap Properties

The **Bitmap Properties** page **Scale** box now displays the scale in relation to the original size, and not the current size.

## Mirror Vertically

There is now a **Mirror Vertically** command which is available from the context menu in **Select Mode**. The previous Mirror command has been renamed **Mirror Horizontally**.

In the illustration below, you can see how the two different mode perform.

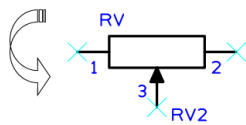
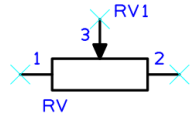

RV1 is the original placement with RV2 Mirrored **Vertically**.

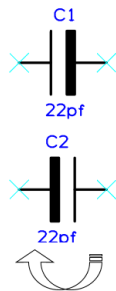

In this example, C1 is the original placement and C2 has been Mirrored **Horizontally**.

## Apply layout pattern

### Copy Copper With Template

A new option, **Copy Copper With Template**, has been added to the **Apply Layout Pattern** dialog. This is available when applying the pattern from a group. If a template is in this group, then enabling the option will now also copy the poured copper associated with it, even if the poured copper is not in the group.

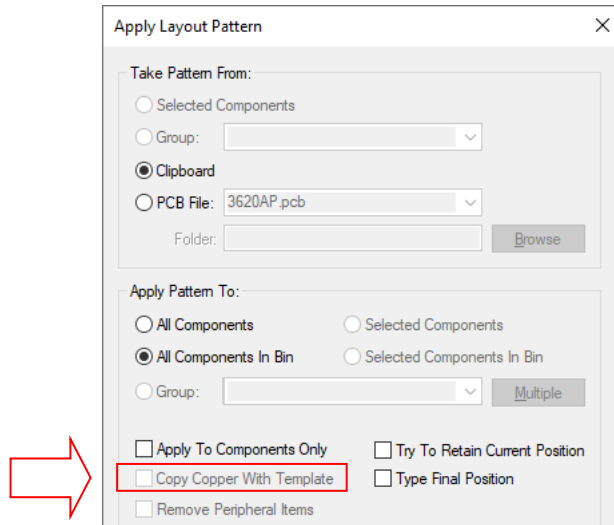

*This feature was back-fitted to V12.0*

### Remove Peripheral Items

The **Remove Peripheral Items** check box has been added to **Apply Layout Pattern**. This option is only available when applying a pattern to a **group**.

When enabled, any peripheral items in the chosen group (Templates, Copper or Text) will be deleted before the pattern is applied. This is useful to avoid multiple copies of templates, copper or text when a pattern that contains these items is applied.

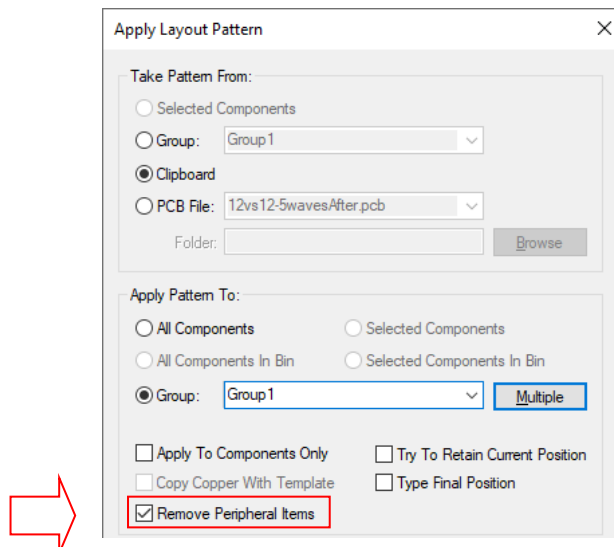

*This was backfitted to V12.0.*



## Cut Shape

You can now select **Cut Shape** from the **Edit** menu.

This takes a single or multiple selected shape(s) and cuts them with a line, the line thickness can be changed. The line can be given a width so that a gap is left between the resulting shapes.

Cut lines can both open and Closed. When a cutting cut is closed, this can be used for creating a shape within a shape; creating shapes that exist as 'islands' in a cutout of another shape can be useful for creating split power planes.

The cut line will avoid creating self-intersection shapes dynamically; finding the next best position for the end of the line that could potentially be reused elsewhere, for example, in Tracks.

The Cut Shape option can also cut open shapes (but only one at a time).

### Context menu options

When setting the cut line, there are other options available on the context menu.

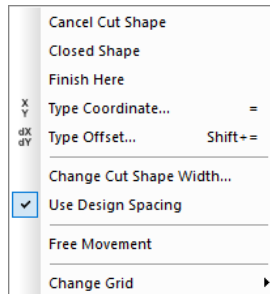

These are standard options but there are two to make note of :

**Closed Shape** - Select this option to make the resultant shape closed. This is useful for creating a shape within a shape.

**Change Cut Shape Width** - Available on all shape types. Use this to set the width of the line used to cut the shape, this determines the gap distance between the resulting shapes. If the width is set to zero (0), the resultant shapes will overlap on their centre (cut) lines.

**Use Spacing** - Available for electrical shapes (Copper, Templates etc.). Select this to use the **Design Spacing Rule** of the item being cut, for example Copper to Copper spacing. This spacing will be used instead of the **Cut Shape Width**.

### The Cut Shape Line Width

There are three cut line 'widths' that can be used (as free widths or Spacings):

User defined as a shape width, This can be either zero size or a defined size. Zero width aligns the **centre lines** of the resultant shapes coincident on top of each other, or as a width, which creates a gap. The gap is also taken between the centre lines.

When using a Spacing rule width, the gap is taken between the **edge** of the shapes.

### Use on Electrical Shapes

Cut shape also considers when shapes are on a net. When cutting a piece of copper or a template a prompt will ask for the net for the new shape to belong to, and this is confirmed after the cut – visually showing which shape will be on which net. The option will automatically use the correct spacing distance specified in the design rules to determine the gap between cut shapes. If multiple shapes are created, you will have an option to set the net of each one in turn.

After cutting, the option will check for DRC errors and notify you if there are any, with an option to undo/cancel the cut.

### Using Cut Shape

Select the **Cut Shape** option and select the shape(s) to cut.



Optionally pre-select the shape(s) you wish to cut then select **Cut Shape**.

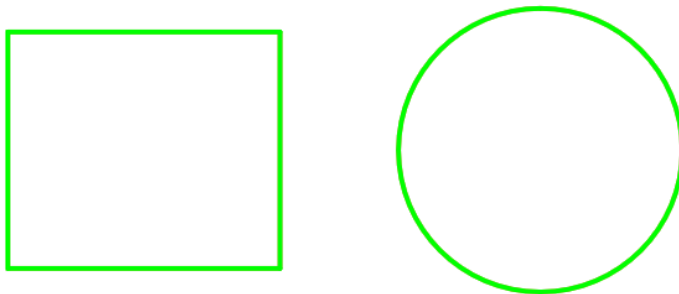

Click to start the cutting line, or drag and drop a straight cutting line.

Continue clicking to add vertices to the line, double-click to finish the line and make the cut.

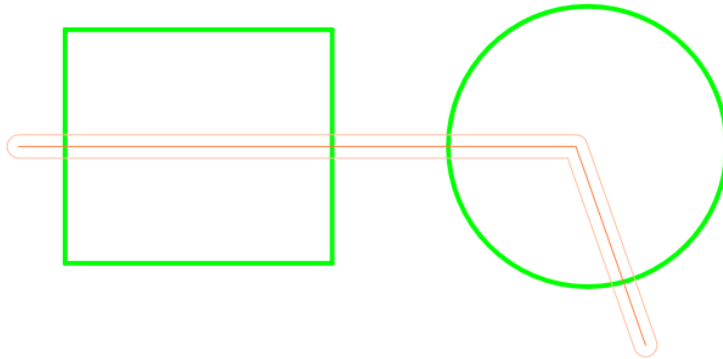

The resulting shapes are left selected, this is ready for another cut if you wish.

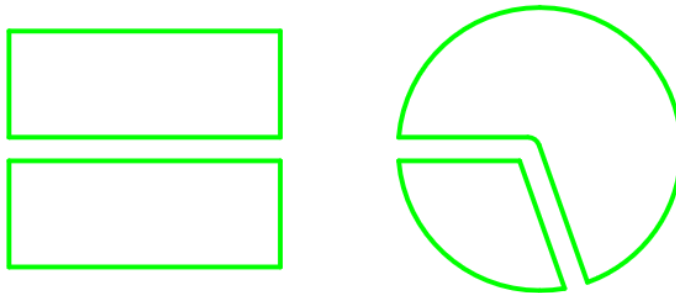

### **Cutting an Electrical Shape**

Add multiple normal shapes that will be converted into cutouts, move them inside the master shape and leave them selected.

Optionally pre-select the shapes you wish to cut. They must all belong to the same net.

Choose or type in the name of the net that the new shape will be.

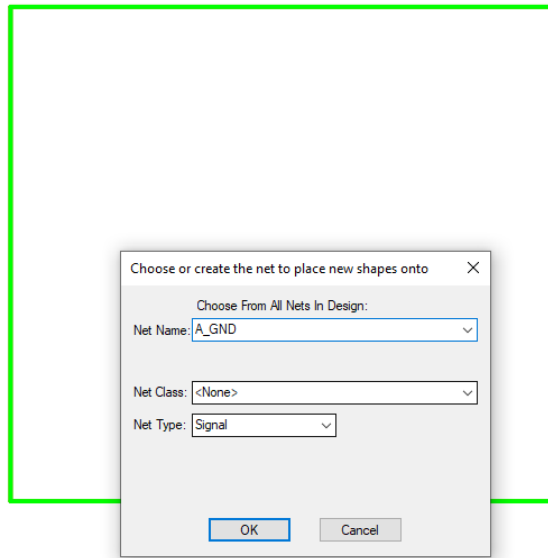

Click to start the cutting line, or drag and drop a straight cutting line.

Continue clicking to add vertices to the line, double-click to finish and make the cut.

If the cut results in two shapes, you can confirm if the highlighted shape is the correct one to place on the new net and choose the other shape if not.

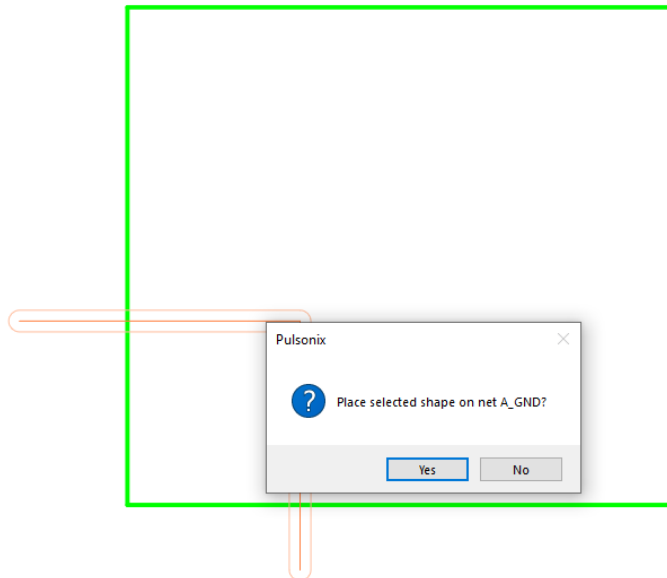

If the cut results in multiple shapes you will be prompted to add each new shape to a net in turn.

After cutting, the new shapes will be checked against the design rules, you will be notified if they cause an error.

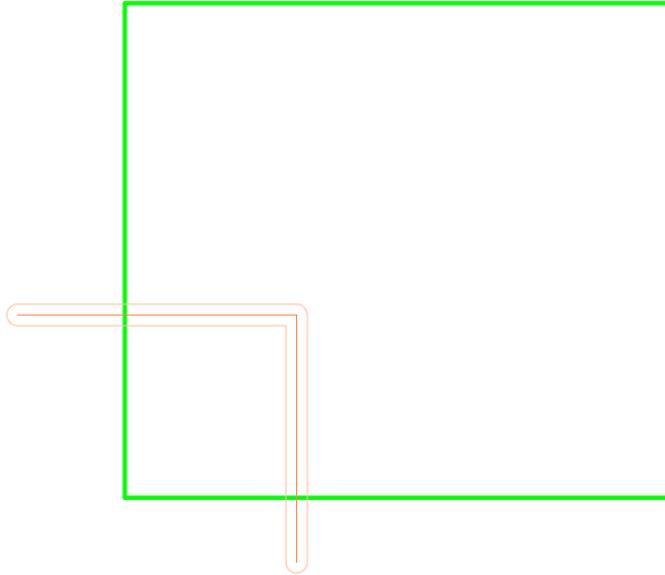

The resultant shapes appear like this:

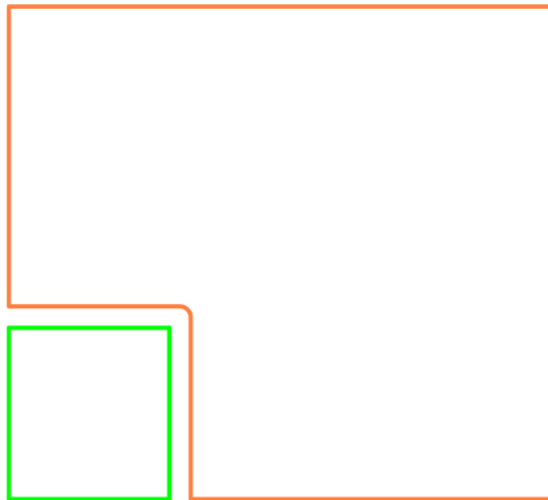

## Improved Wave Shape Generation

The **Wave shape** generator has been changed to provide better accuracy at lower **Segments Per Period** settings.

A result of this change is that the number of **Segments Per Period** in the wave will now be a multiple of 4 (it will be rounded up to the nearest multiple of 4 if not).

If the number of segments is exactly 4 it will generate a triangle wave.

An extra field has been added to show you the **Actual Segments Per Period** based on the number of **Segments Per Period** typed.

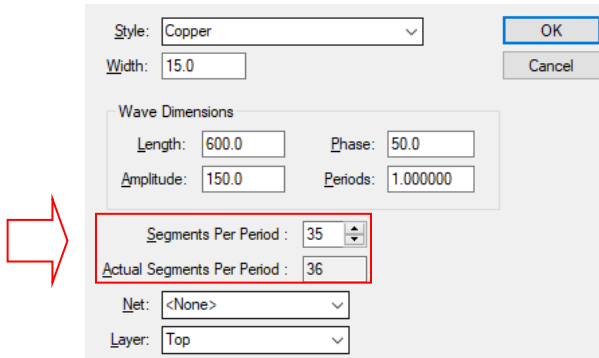

## Construction Line Changes

### New Construction Line Shapes

There are new Construction Line shapes available for Rectangle, Triangle, Polygon, and non-infinite lines. These appear on the construction Line menu and are discussed below.

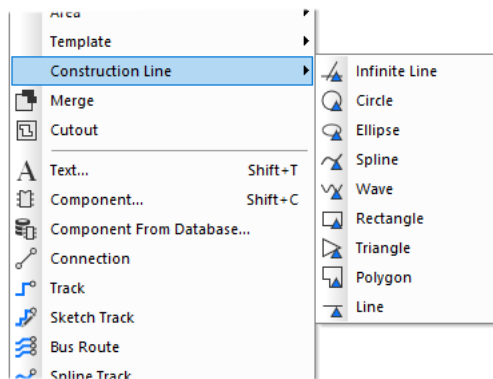

### New Non-infinite Construction Line option

Construction Lines can now be partial and not always infinite, for example, where three lines divide a circle. In this instance, the three lines meet in the centre of the circle but the lines extend outside the circle to infinity.

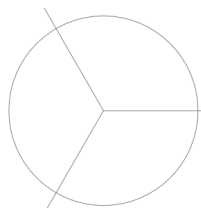

The other example is where both ends of the line are inside the design area, and neither end is outside of this to infinity.

### New Line Options

The old **Line** option has been renamed to **Infinite Line**.

A new non-infinite Line option has been added to the menu and is called **Line**.

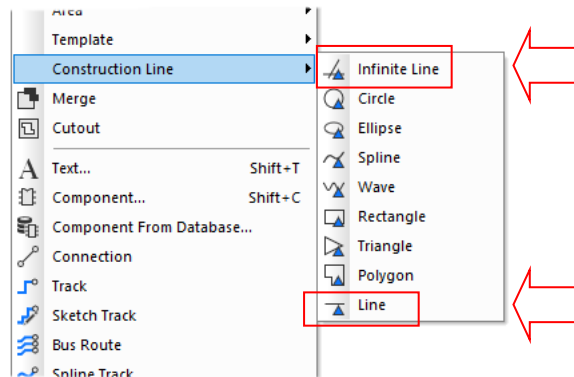

### Change Shape to Construction Line

The **Change Shape Type** and **Replicate Shape As** options can now be used to change a shape to a **Construction Line**. This will convert the shape or line into non-infinite Construction Lines.

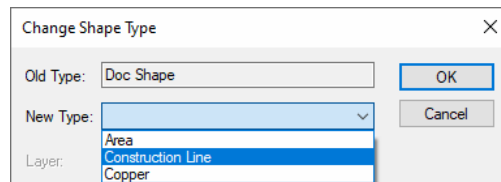

*This feature was back-fitted to V12.0 but only for circles, splines and ellipses. In V12.5, the full shape range is available*

### Clip Construction Lines

#### Clip Construction Line

There is a new option available on the **Edit** menu to **Clip Construction Line**. This allows you to clip any Construction Line using a box, so that the cut shape fits inside the box. This enables you to have non-infinite Construction Lines with a region. This declutters your screen if you have many Construction Lines defined and also helps you focus on one particular area.

The default mode uses a **box** to clip the lines. To clip between two lines select the **Clip With Lines** option on the context menu.

### Clip with Lines

While in this mode, using the context menu, you can change to the **Clip with Lines** option which will clip the Construction Line to be between those lines (similar to cut track). This option only works on 'open' Construction Lines.

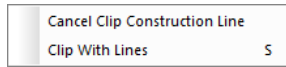

### Using a Box to Clip

Use two left mouse clicks to define the start and end points of the clip box, or drag the cursor to draw the clip box.

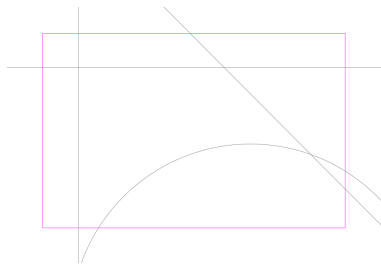

The Construction Line(s) will be cut to fit inside the box.

### Between Two Lines

Use two left mouse clicks to define the start and end points of the first cut line, or drag the cursor to define the cut line.

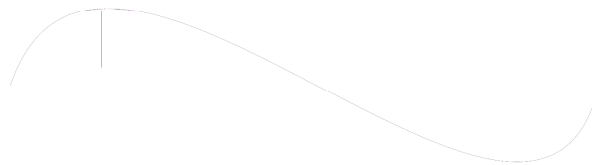

A second dynamic cut line will be displayed at the same angle and length as the first line for you to position with your cursor. You can use the Rotate option from the shortcut menu to rotate this line.

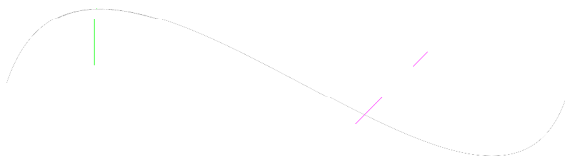

Drop the second cut line over the Construction Line(s) to cut them between the two cut lines, or drop the second line past the end of Construction Line(s) to cut them from the first cut line to their ends.



Note: This option will only work on 'open' Construction Lines.

## Edit Shape Using Construction Lines

There is a new option for adding regions to or chopping regions out of a selected shape. With the shape selected, the option can be accessed from the context menu, **Edit Shape Using Construction Region**. This new mode works with Construction Lines with any sequence of straight or arc segments.

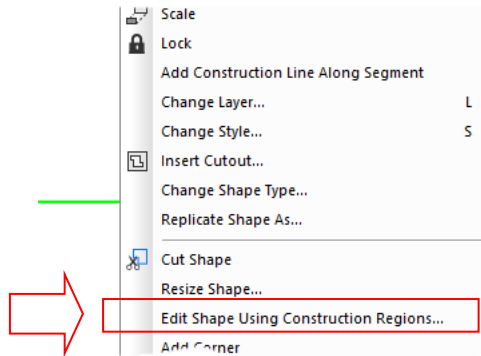

This means that one Construction Lines are added to and around shapes, the shape can be modified based on regions without having to manually select segments, move them and snap to the Construction Lines.

Once the **Edit Shape Using Construction Region** option is selected from the context menu of a selected shape, a selection region indicator is displayed. This will be either a solid shape to indicate the shape will be modified outwards, or a dotted region shape to indicate the shape will be modified inwards. If the shape can only be modified in one direction, then only the solid indicator is shown. Sometimes, regions can't be selected because they'd cause self-intersecting shapes.

Below are two examples, showing the two styles of region modification:

Shape modified outwards (region as a solid line):

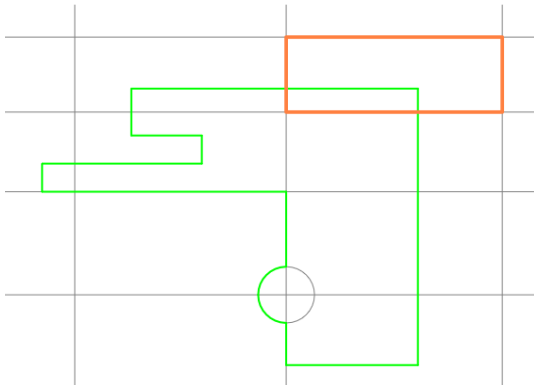

Resultant Shape:

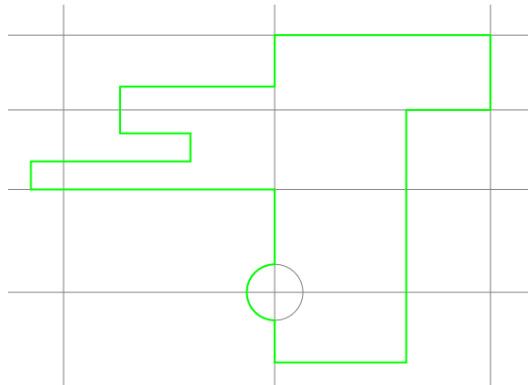

Shape Modified Inwards (showing region dotted):

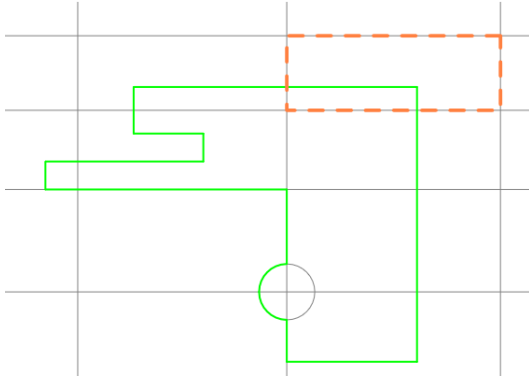

Resultant Shape:

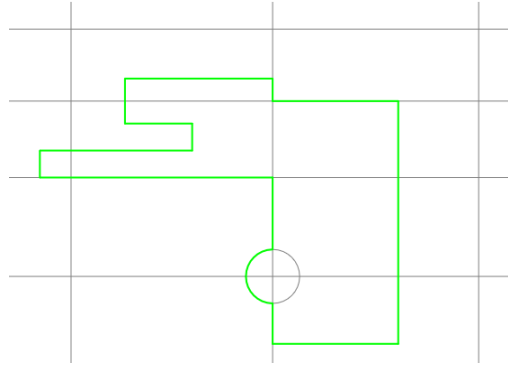

### Add Construction Line Along Segment(s)

With a shape segment or segments selected, from the context menu, you can now add Construction Lines along these segments. This will add infinite lines along those selected segments. This option means you can quickly add multiple, and often complex, constructions lines to a shape from where you can modify the shape using other interactive features, such as **Edit Shape Using Construction Lines**.

Note, the shape can be curved as well as a straight line segment.

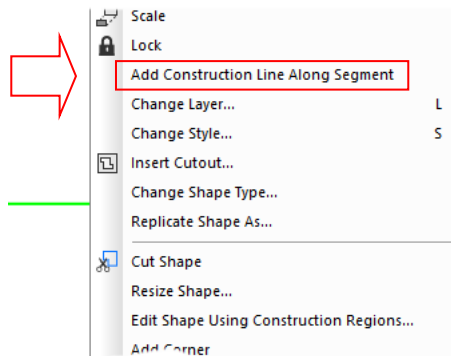

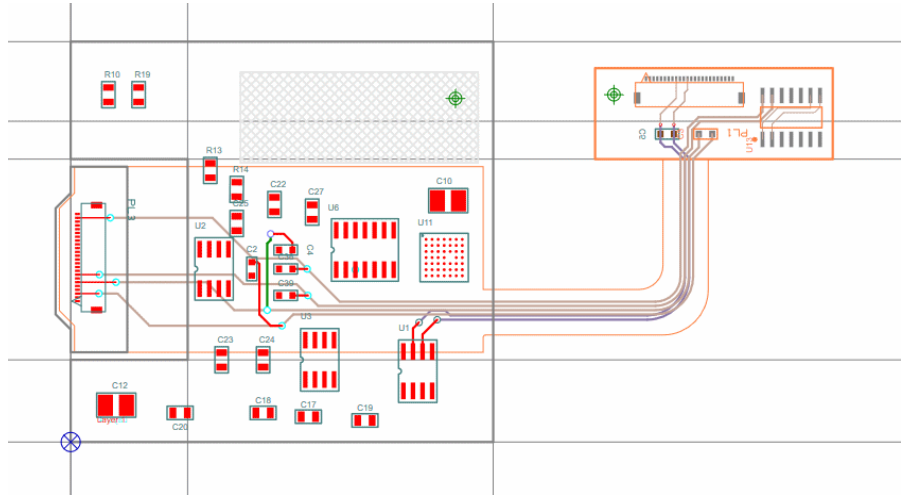

## Set Tangent Angle

Using **Enter Angle** when adding a tangent sets the tangent angle, and finishes at that angle.

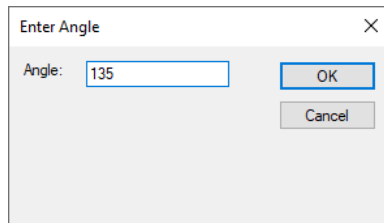

This enables you to place a line at an exact tangent angle required.

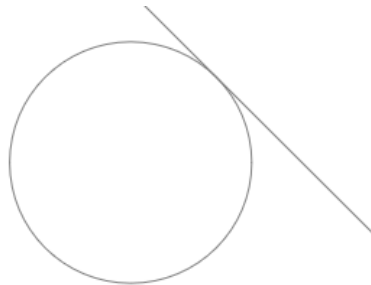

## Snap to Construction Line - Vias

The option, **Snap to Construction Lines** has been added to the context menu when moving **Vias**.

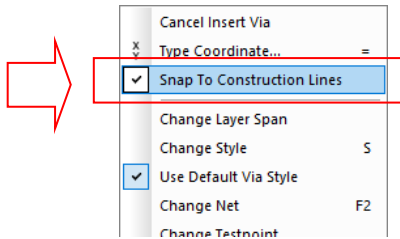

### Named Construction Lines

You can now name Construction Lines in their **Properties**. These names can be made visible by ticking the check box. With this, Construction Lines have been added to the **Find bar** so you can locate them.

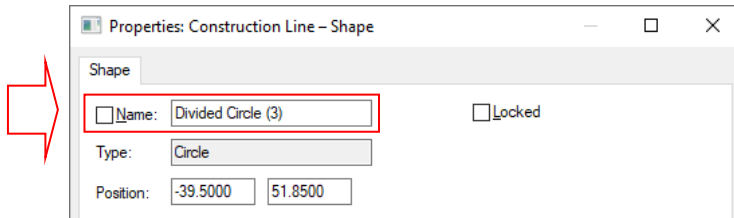

### Divide Circle by an odd number

You can now use Construction Lines (Infinite Line) to divide circles by an odd number, like 3 or 5, this will create semi-infinite lines (infinite in one direction).

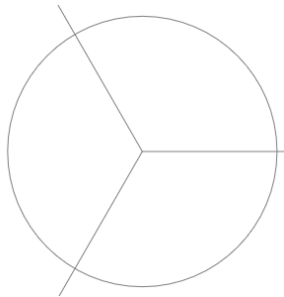

## CAM Plot Changes

### Plot Transformations in CAM Plot Preview

The **Plot Preview** page has been changed so that where multiple layers are defined using the **Add To Plot** option, they can be individually transformed in the **Preview** window.

Where multiple plots have been defined using the **Add To Plot** option, the currently selected plot will be highlighted in orange. The original plot that the others are based off will be shown in black.

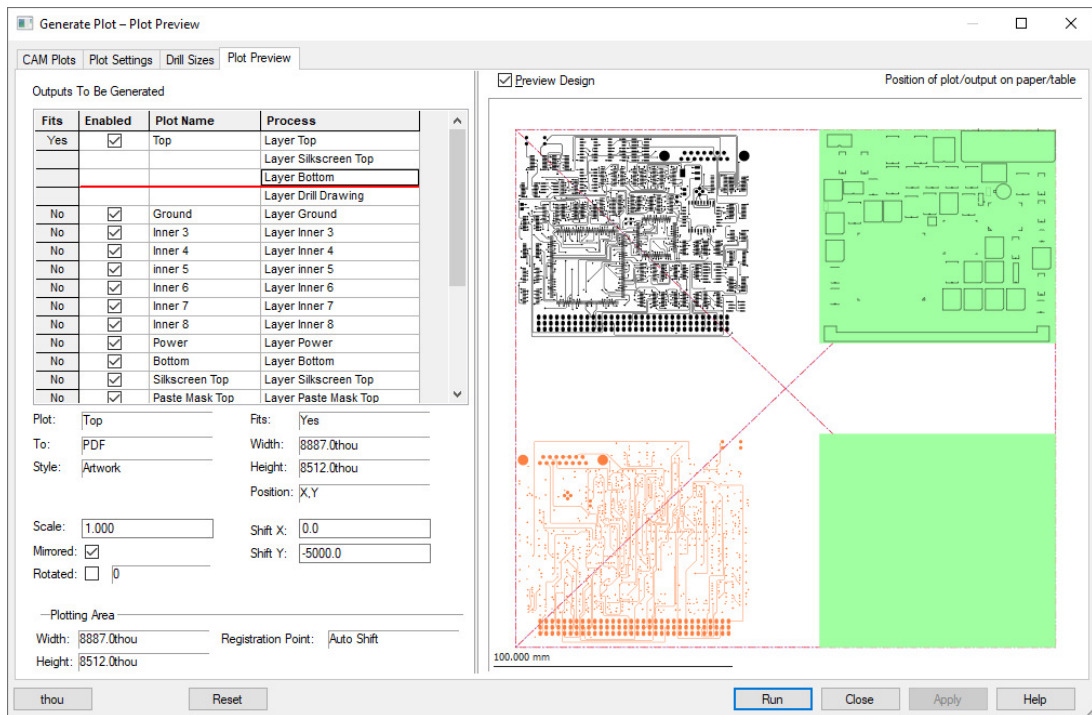

Any transformation performed is given relative to the **Plotting Area Registration Point**.

The transformation is given relative to the **Plotting Area Registration Point** (hence the Shift X & Y will be different values to those specified on the **CAM Plots** page, which give the registration point relative to the design origin.)

The **Reset** button at the bottom of this dialog is used to cancel any pending edits.

Fields can be edited to transform the position of individual plots (where more than one has been defined using the **Add To Plot** option). You can edit the **Scale**, **Mirrored**, **Rotated**, **Shift X** & **Shift Y** values on this dialog. Equivalent values will be set on the original plot where multiple plots are defined.

Plot:  Fits:   
 To:  Width:   
 Style:  Height:   
 Position:

Scale:  Shift X:   
 Mirrored:  Shift Y:   
 Rotated:

— Plotting Area —

Width:  Registration Point:   
 Height:

The **Shift X** & **Shift Y** values can be defined positively or negatively, depending on how you require the plot to be shifted on the bed relative to the original plot.

## Splitter Control in CAM Plot Preview

The **Plot Preview** page now has a splitter bar. This means the Preview window can be resized to your requirements. It also makes the information page resizable to enable you to see more information.

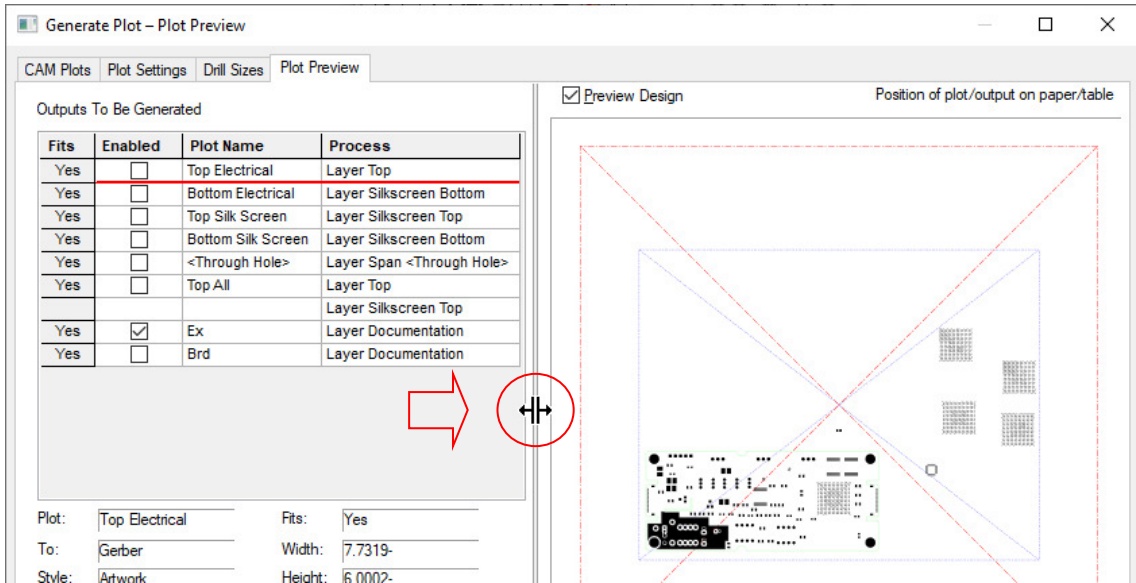

## Gerber Plot File Extensions

You can now define the file extension explicitly for a Gerber plot. you can explicitly

For a **Gerber** plot, you can now specify an explicit file extension. This will override the default file extension for this plot only. Leave this field blank if you want to use the default extension for this type of output. This is available from within the **CAM Plot** option, and **Plot Wizard**, **Process** page,



The screenshot shows a dialog box with several fields: 'Name' (Top Layer), 'Plot Group' (dropdown), 'Plot String' (text), 'Output To' (Gerber dropdown), and 'File Extension' (.gbr). A red box highlights the 'File Extension' field, and a red arrow points to it from the left.

## PDF Plot - Zoom on a Clickable Link

In the **CAM Plot** dialog, on the **Plot Settings**, within the **PDF Setup** dialog, there is now an option **Zoom On Clickable Link** which if disabled will prevent the PDF viewer from zooming into the target of a clickable PDF link and instead just do the pan (centre view). An example of a clickable link is the **Push into Block** annotation link.

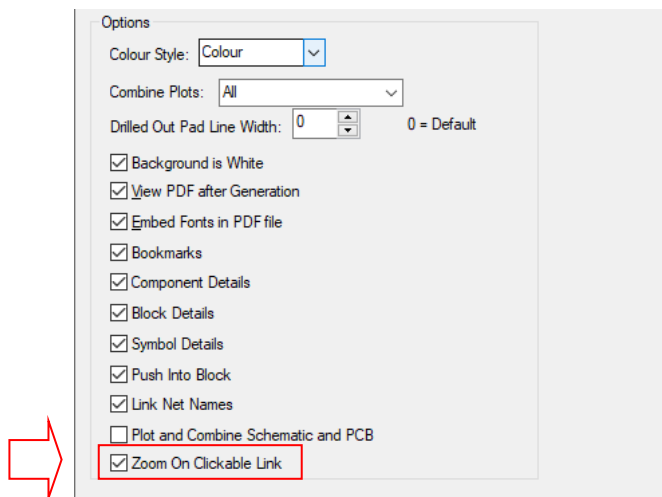

The screenshot shows the 'Options' section of a dialog box. It includes several settings: 'Colour Style' (Colour dropdown), 'Combine Plots' (All dropdown), 'Drilled Out Pad Line Width' (0 spinner, 0 = Default), and a list of checkboxes: 'Background is White', 'View PDF after Generation', 'Embed Fonts in PDF file', 'Bookmarks', 'Component Details', 'Block Details', 'Symbol Details', 'Push Into Block', 'Link Net Names', 'Plot and Combine Schematic and PCB', and 'Zoom On Clickable Link'. The 'Zoom On Clickable Link' checkbox is checked and highlighted with a red box, with a red arrow pointing to it from the left.

## PDF Plot - Customise Drilled-Out Pad Line Width

You can now change the stroke width (line width) of drill holes that do not have their pads drawn.

Previously, drilled-out pads were drawn with single-pixel line which can be very difficult to see on the PDF printout.

You can now do this by using the **PDF Setup** dialog and changing the value of the option **Drilled-Out Pad Line Width**. You can have an integer value in the range of 0 and 10, where zero is the default value. The higher the value the thicker the stroke.

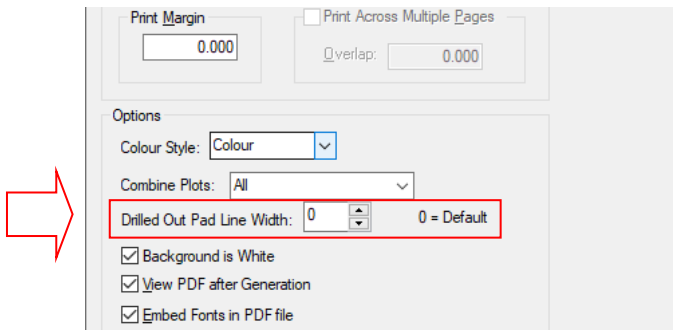

### DXF Output – Save settings

**DXF Output** now saves all of the selected settings and layers to the registry for Schematic and PCB designs. This means that in addition to saving the settings to the registry when outputting a DXF file via the **Output** menu, the settings can also be saved to the design through the **CAM Plot** mechanism where the plot will keep track of the output settings.

#### DXF Settings in Configuration Files

The **DXF** setting will get saved to the Registry which means it can be transported to another machine when saving a **Configuration File**. Note, these settings are no saved to the Technology but are saved into the **CAM Plot** settings when used, which are therefore saved into the design and Technology file.

### GenCAD Output

#### Multi-Threading use for Processing GenCAD Files

You can now use multiple threads when outputting **GenCAD** files using either the **Output** menu or the **CAM Plots** dialog. The vast majority of time spent is in calculating complicated copper shapes and so each copper item is calculated in a separate thread. On average, this process is now 66.6% faster, with ~76% being the upper end of the speed increase seen.

#### GenCAD Settings Saved

**GenCAD plots** now support the ability to save the **Layers** and/or **Layer Class Names** that are selected.

In the **CAM Plot** dialog, the GenCAD settings are now saved with the plot setting and hence with the design and Technology.

The **GenCAD** setting will get saved to the Registry which means it can be transported to another machine when saving a **Configuration File**. Note, these settings are no saved to the Technology but are saved into the **CAM Plot** settings when used, which are therefore saved into the design and Technology file.



## GenCAD Dialog Rearranged

The **GenCAD** dialog has been rearranged slightly to more logically group function buttons and for new options.

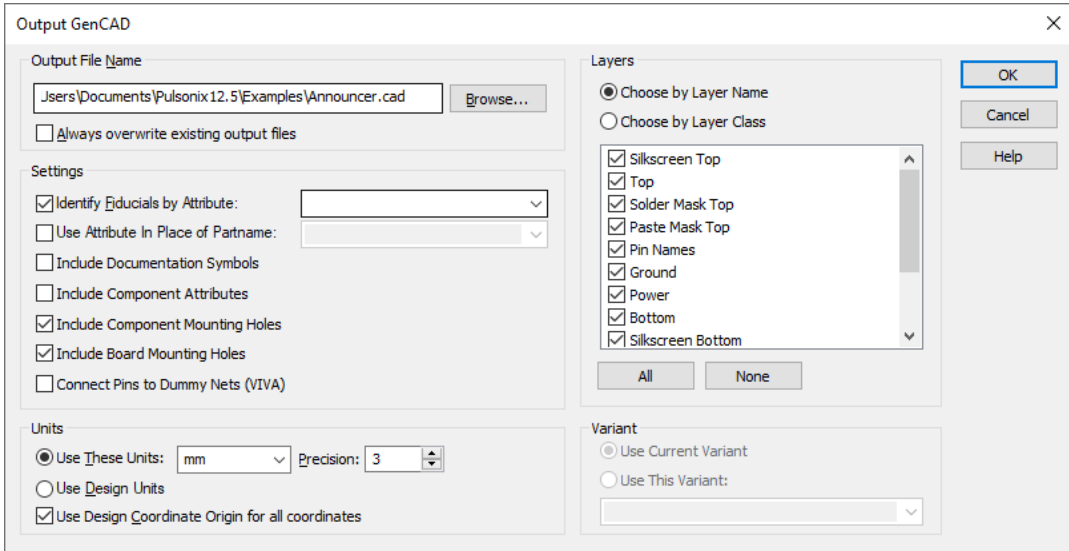

## Select Output by Layer or Layer Class

There are two radio buttons and a check list box on the **GenCAD Output** dialog allowing you to selectively output data by layer or layer class.

This is to help suppress the output of items like drawing outlines outside the board. This layer only applies to shape-based items including doc shapes, copper and tracks, it will not do things like suppress layers within pad stacks.

When switching between **Layer Name** and **Layer Class** using the radio buttons, the check box updates with the relevant information.

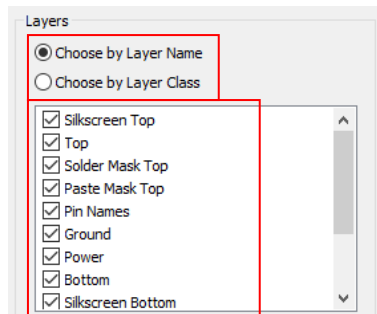

### Output Board Level Mounting Holes Class

Two new check boxes allow you to output board (design level) **Component** (footprint) **Mounting Holes**, **Board Mounting Holes**, or both (by selecting both check boxes).

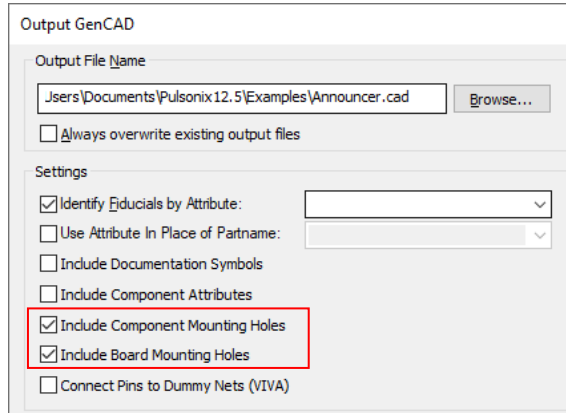

### Output Current (or Named) Variant

There are now options to only output the **Current** (or named) **Variant**.

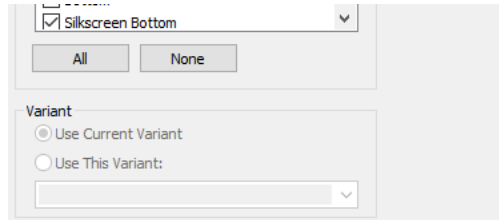

### Panel Editor

#### Interaction Options

In the **Options** dialog, **Interaction** and **Panel Interaction**, the **Create Tab-Rout Around PCB Avoids Existing Tab-Routs** option had been split into two options.

**Avoid Existing Tab-Routs**, this will back off the tab rout so it doesn't cover an existing tab-rout.

**Back Off by Tab Width**, this will back off by the tab width set in the Panel Tab-Rout defaults and add mouse bites if they're enabled.

With both options off the tab-rout will rout over the existing tab.

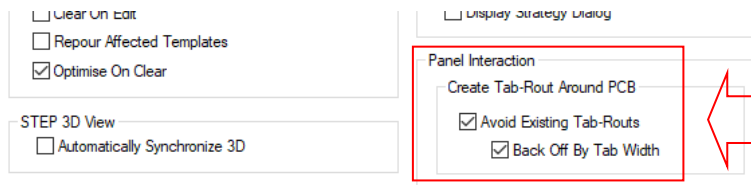

## Apply Tab-Rout to All Instances

When you have a PCB instance selected in the Panel Editor, there is a new **Apply Tab-Rout to All Instances** option available on context menu. This will take the existing tab-rout pattern and copy it to all similar PCB instances in the panel.



## Double Row Mouse Bites

You can now add a 'double' row of mouse bites when creating tab routs.

There is a new **Double Row** setting in the **Technology** dialog, **Design Settings, Defaults** and **Panel Tab-Rout**. This will force a double row mouse bites when you add a breakout tab.

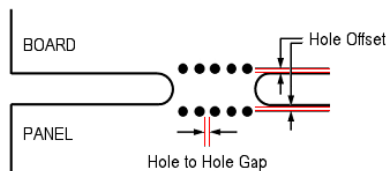
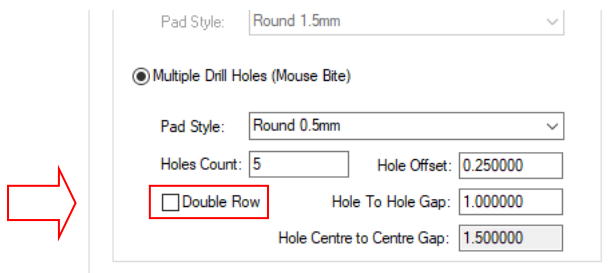

Doubles row mouse bites will be automatically added when you have two PCB instances adjacent to a tab-rout.

### Hole Centre to Centre Gap

There is also a new non-editable entry displaying the **Hole Centre to Centre Gap**. This is a calculated value using the **Pad Style Drill Diameter** plus **Hole To Hole Gap** value. This is for information only and helps you assess the drill hole distance.

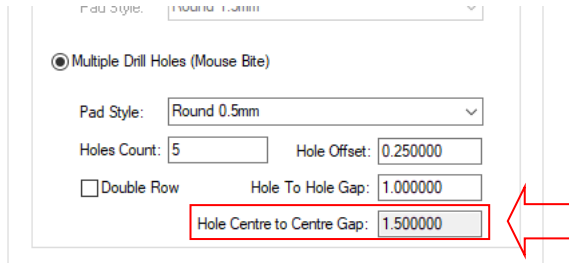

### Intelligent Gerber Import – New Data Type - Placement CSV

Within the **Intelligent Gerber Import** option, **Pick and Place CSV** data can now be used as an alternative to **BOM** data for adding components to the design. This data type has the added benefit over importing a BOM in that it can also intelligently weld them into place the components into the design based on their placement positional data.

This feature will take components from the library using library items already created. The library (the footprint specifically) must be orientated to match the original orientation in the Placement file, which in turn, represents the same orientation in the design. That means, if the original design had the footprint created vertically, then the new Pulsonix must also have the footprint created in this orientation. If not, the placement file will orientate/rotate the new component/footprint 90 degrees out of position.

The **Part name** used in the Pulsonix library must match the Placement file Part name used.

During import, it will attempt to line up Components with the other imported Gerber data, such as pads. Once aligned, it will weld the components into position and delete the original pads underneath.

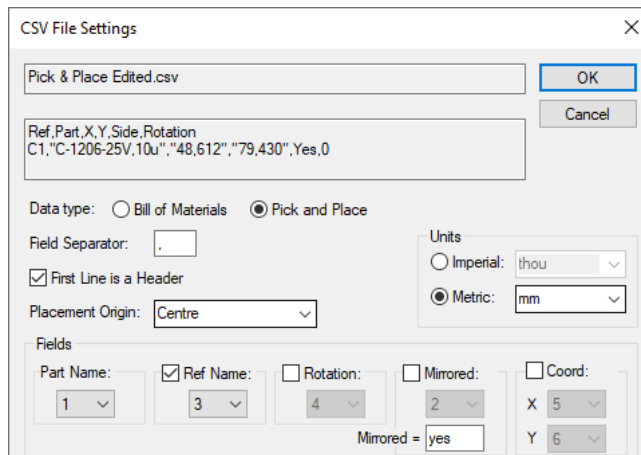

Once placed and aligned, the components are then welded into place and replace the associated pads underneath the component.

## Generate Component Dialog improvements

Using the interactive **Generate Component** option from a selected component in the PCB design, the dialog had been reorganised to make it more logical to use.

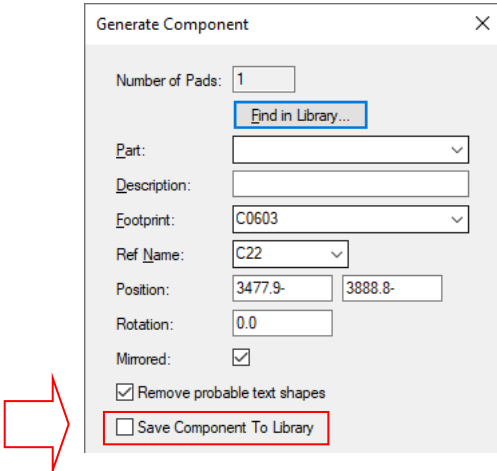

A check box has been added **Save Component To Library** which will show the **Save To Library** dialog after the **Generate Component** dialog closes.

You can now also edit the values in any of the fields in the dialog to change what the values will be in the generated component. If you choose a ref name which is a component in the bin it will replace that component with the generated component.

## PDC Database Bar – Splitter Controls Added

Splitter controls have now been added to the **Database** bar to adjust the sizes of the search, results and preview sections.

When docked on the left or right the sections will be arranged vertically, and when docked on the top or bottom the sections will be arranged horizontally to make the best use of available space. These sizes are stored in the registry on program close allowing section sizes to be remembered between sessions.

Splitters are available on the side of the **Preview** window and above the **Results** window:

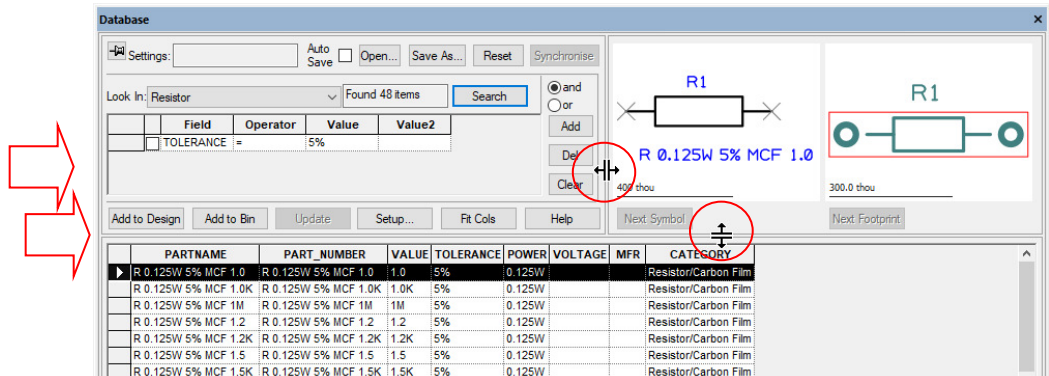

When the dialog is resized sufficiently at the right edge, the Preview window will drop to the bottom of the dialog. From here, splitters allow the Results and Preview windows to be resized.

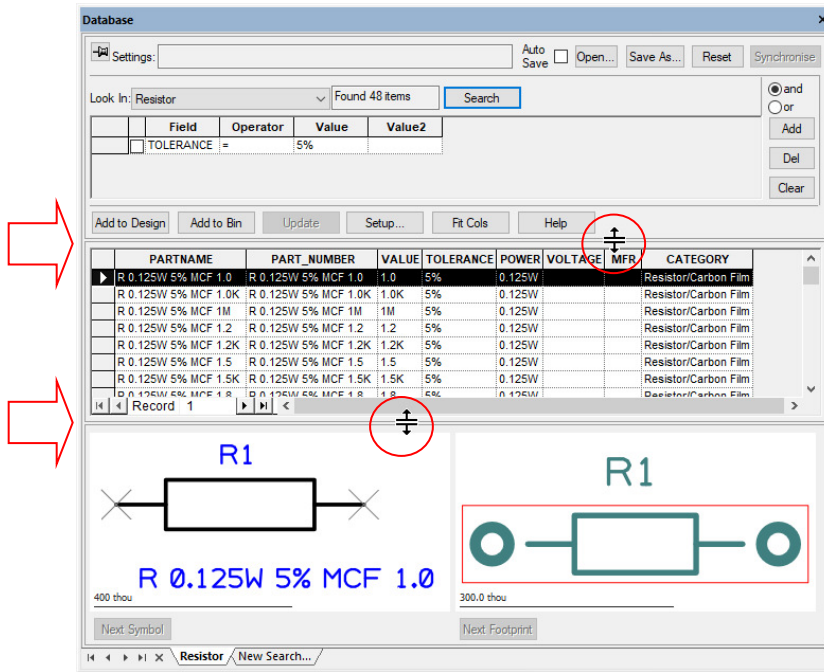

## Variants

### Doc Shapes

You can now have **Variant Doc Shapes**. A doc shape is added to the design and then using **Properties** of the shape, you can define which **Variant** the shape is fitted in.

This is a PCB only feature and is not available in Schematics.

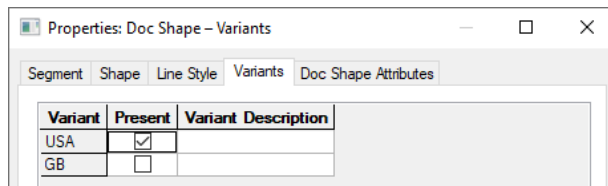

### Multiple Select Fitted/Not Fitted Components

You can Fit (or Unfit) multiple components in one hit using the **Component Variant Spreadsheet** from the **Edit** menu.

You can do this by using the Ctrl and Shift keys to select the required components in the spreadsheet list.

Once selected, the **Variant Details** pane changes to a simplified version that only allows the fitted status to be changed.

Component Variant Spreadsheet

Name	USA	GB*
C1	C	C
C2	C	C
C3	C	C
C4	C	C
C5	C	C
C6	C	C
C7	C	C
C8	C	C
C9	C	C
C10	C	C
C11	C	C
C12	C	C
C13	CP	CP
C14	C_Height	C_Height
C16	C	C
D1		
D2	D	D
D3	D	D
D4	D	D
D5	D	D
D6	D	D
D7	D	D
D8	D	D

Component: C[1-2],C[5-7]    Update Spreadsheet    Discard Changes

Variant	Fitted
USA	<input checked="" type="checkbox"/>
GB*	<input type="checkbox"/>



Once your changes have been made, either select **Update Spreadsheet** or **Discard Changes** to make the changes permanent or to discard them.

*This was backfitted to V12.5.9451*

## Vault Changes

### Underlying Vault Technology Changes

For the Version 12.5 release, there have been underlying changes and updates to the following core technologies:

ODBC Driver V13.0

PostgreSQL server V14.5

Pulsonix Vault database V12.5

In order to successfully run the Pulsonix V12.5 Vault, all three technologies should be updated.

### Updated ODBC Driver

The V13.0 ODBC driver will be automatically installed during the main Pulsonix product installation. The driver is required on the Pulsonix client side. This new driver is required in order to support the Postgres server V14.5.

If, for some reason, the automatic install has not been successful, the driver installer will be available in the Vault Admin install folder, normally at “C:\Program Files\Pulsonix Vault Admin 12.5“. The file is named **psqlodbc\_x64.msi** and should be run under your system administration permissions.

### Updated Vault Setup ODBC Drivers

If you run the V12.5 Vault and the old ODBC driver is used (if you have used a previous copy of the Vault), this can be changed from with the **Vault Setup** dialog.

From the **Vault Setup** dialog, **Sign In** page, alter the ODBC driver used to connect to the **Vault Database** using the **Change** button. You should now be using the V13.0 x64 driver for V12.5.

The screenshot shows the 'Sign In' dialog box with the following details:

- Tab: Sign In
- Radio buttons:  Primary Sign-in,  Alternate Sign-in
- User Name: Admin
- Password: [masked with 7 asterisks]
- ODBC Driver: PostgreSQL ANSI(x64) (highlighted with a red box and arrow)
- Server Name: localhost
- Server Port: 5432
- Data Folder: [empty]
- Vault ID: [empty]
- Buttons: Test, Login Status: Signed Out, Sign Out

The **Change** button will open the **Change ODBC** driver dialog. From here you can select a Postgres ODBC driver from a list of currently installed drivers on your computer. Otherwise, you can press the 'Default' button to select the default Vault ODBC driver. Also, when testing a connection, Pulsonix will attempt to use the driver you've specified, if it fails, it will automatically attempt to find and use an alternative driver. If one is found, you will be prompted that their selection does not work but this found working driver will be used.

### Checking the ODBC Drivers

You can also check the status of the ODBC drivers using the Windows ODBC Driver dialog.

To access this, from the **Windows Start** menu, type in **ODBC**. Select the **ODBC Data Sources (64-bit)** application:



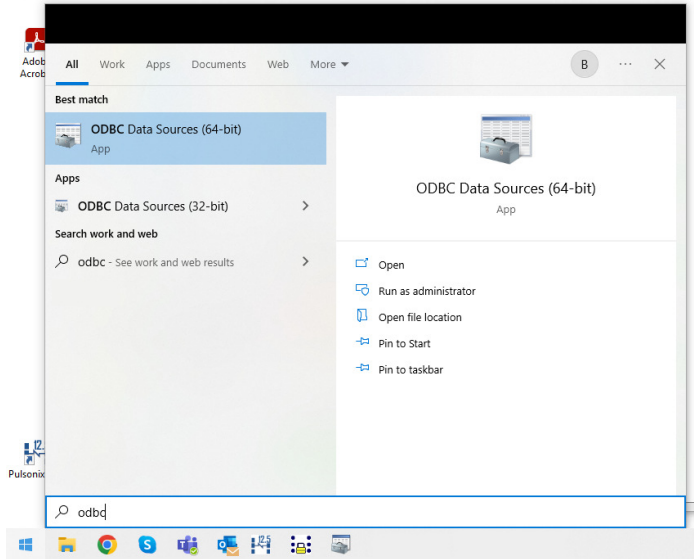

From the dialog presented, choose the **Drivers** page. You will see the **PostgreSQL ANSI(x64)** driver listed.

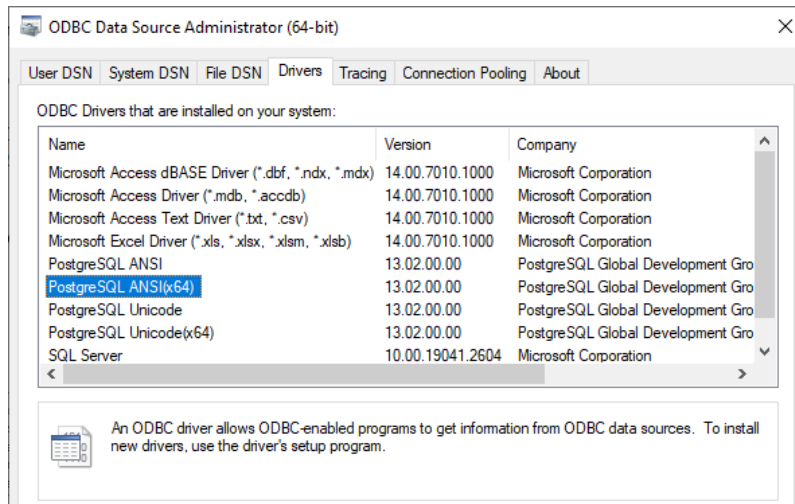

If, for some reason, this hasn't worked or been successful, the driver installer will be available in the Vault Admin setup. You can locate this under the C:\Program Files\Pulsonix Vault Admin 12.5 folder. The file is named **psqlodbc\_x64.msi** and should be run under your system administration permissions.

### Updated Vault Postgres Server to V14.5

The Pulsonix Vault now uses Postgres server version 14.5. The supplied Pulsonix Vault Server Setup for V12.5 has been updated to reflect this change and will now install a 64-bit V14.5 Postgres server.

This new program will be installed when you run the **Vault Server Setup** program supplied for Pulsonix V12.5.

#### Existing Pulsonix12.0 Vault Users

Pulsonix12.0 users that have already been using the Vault with PostgreSQL V9.5 (x86) should still run the Pulsonix12.5 **Vault Server Setup** program to install the 64-bit V14.5 Postgres server alongside the V9.5 version. Prior to doing this, the Pulsonix 12.0 **Vault Admin** program should be run, as described below in the “*Vault Database Update - Backup your existing Database*” section, to create a backup of the Pulsonix 12.0 Vault.

During the **PostgreSQL Setup**, started by **Vault Server Setup**, the Port number to be used for PostgreSQL V14.5 will be automatically incremented from the one used for the previous PostgreSQL V9.5 (e.g. 5432 to 5433). This different Port number will allow Pulsonix to distinguish between the two versions of PostgreSQL.

If so desired, the old PostgreSQL V9.5 (x86) may be removed once the new PostgreSQL V14.5 is successfully set up and running the Pulsonix12.5 Vault. Please note that this new incremented port number will now be the permanent Postgres port in use by the Vault.

The **Vault Server Setup** step 2. **Create Vault Database** should be performed to create the Pulsonix environment in the new PostgreSQL V14.5 server remembering to set the Port number to the incremented V14.5 value. The new empty Vault database created now needs to be replaced with the Pulsonix 12.0 backup by running the **Vault Admin** program installed with Pulsonix12.5. This is described below in the “*Vault Database Update – Restoring the Database*” section.

Pulsonix12.5 should now be launched and the **Vault Setup** dialog opened. On the **Sign In** page the **Server Port** should be changed to the incremented V14.5 value and the **Test** button clicked. If successful, the **Ok** button should be clicked to save the modified Port number.

The “*Vault Database Update*” procedure described below should now be performed.

### Vault Database Update

An updated Vault is used for Pulsonix V12.5 to support the new functionality.

For new users to the Vault, all the latest V12.5 Vault features and permissions will be included in the newly installed Vault database.

Existing Pulsonix12.0 Vault users need to update your Vault database version to support Pulsonix12.5 functionality, by following the steps below.

## Backup your existing Database

You should first run the **Backup** tool in the existing **Vault Admin** program supplied with Pulsonix V12.0.

Use the **Vault Admin Backup** tool to do this:

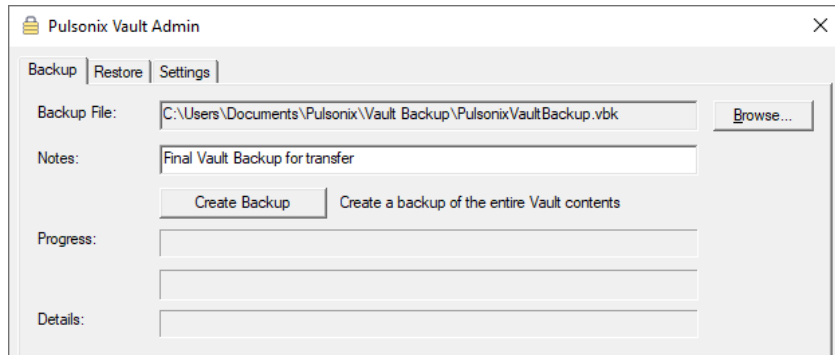

## Updating the Database

Using the **Vault Server Setup**, you should have previously installed the **Postgres** server (using Step 1. on the dialog) so that Version 14.x is available.

During the **Vault Server Setup**, you should have previously installed and created a new Vault database (using Step 2.). Existing Pulsonix12.0 Vault users should have previously transferred the Vault database to PostgreSQL V14.x.

The main Pulsonix V12.5 should have been installed on the client machine. This will have also updated the ODBC driver to V13.0.

For existing Vault 12.0 users, you will need to follow the steps described in the “*Vault Database Update – Admin Permissions*” section and the “*Vault Database Update – Updating the Version*” section.

## Restoring the Database

When the Pulsonix12.5 **Vault Admin** program is first run it will still show the **Settings** from Pulsonix12.0. These will need to be changed so the backup is restored for Pulsonix12.5 instead of Pulsonix12.0. The Port number will need to be changed to the incremented V14.5 value mentioned earlier, and the Postgres Folder will need modifying to use the newly installed 64-bit PostgreSQL V14.5, normally, from “C:\Program Files (x86)\PostgreSQL\9.5\bin” to “C:\Program Files\PostgreSQL\14\bin”. On the **Vault Admin - Restore** tab, the Pulsonix12.0 backup should then be loaded and the **Restore existing** option used to restore the Vault database into PostgreSQL V14.5 ready to be used in Pulsonix12.5.

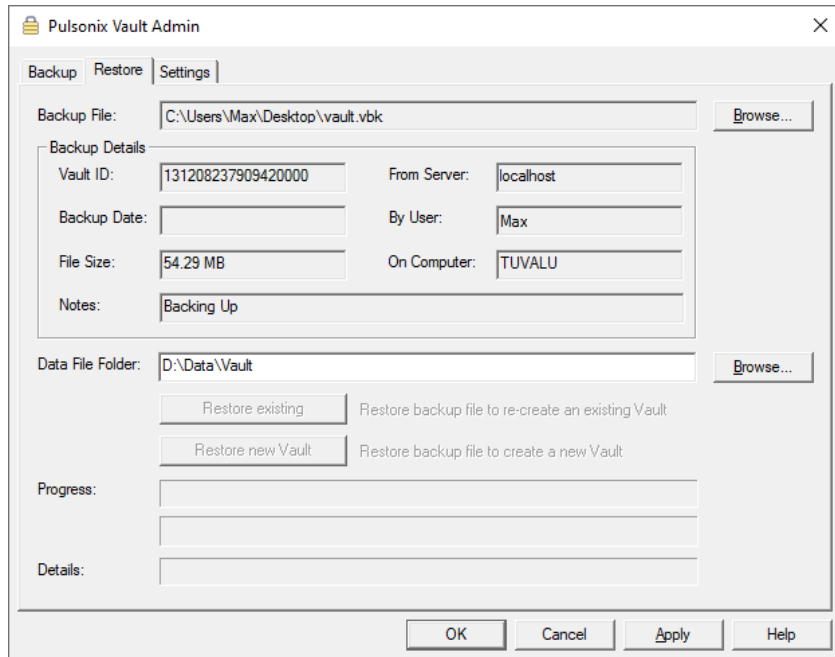

### Admin Permissions

To update the Vault version, the person who is administering the update must have **Database Maintenance** permissions.

From within the main Pulsonix application, on **Vault Setup**, the **Admin** permission under **Groups** must have **Database Maintenance** permissions set.

If you are not updating from an existing Vault, the **Admin** group will already contain the required **Database Maintenance** permission. Otherwise, you will need to create a new group and user, or using an existing **non-admin** group and user, update the permissions of that group to contain **Database Maintenance**. Once the update has been complete, the existing **Admin** group will be automatically updated with the **Database Maintenance** permission.

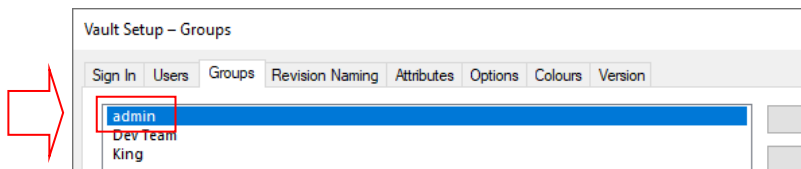

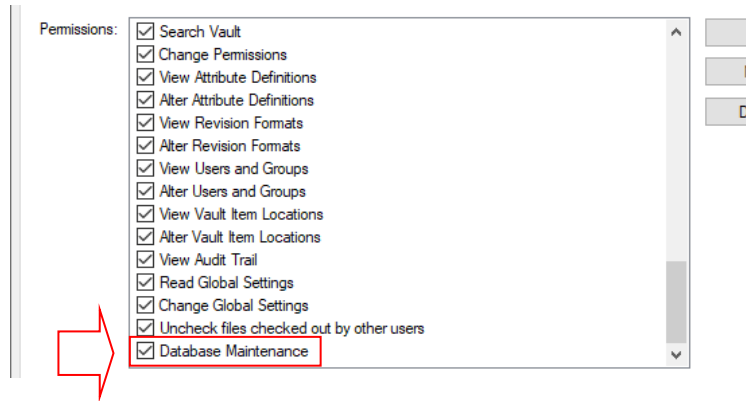

### Updating the Version

When logged in as a user with the **Database Maintenance** permission, you will now see the **Versions** tab in the **Vault Setup** dialog.

When a Vault format update is available, the **Update** button will be enabled. You will also get the update notification every time you launch the **Vault Manager** dialog. This notification can be turned off in the **Warnings** page within **Options** under **Prompt Vault Database Updates**.

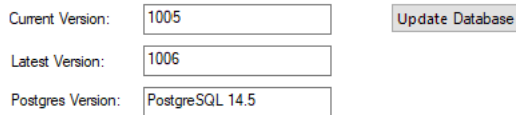

Again, before updating, we highly recommend that you perform a full Vault backup from the **Vault Admin** application. When ready, you can proceed by clicking on the **Update** button which will handle the updating process.

Confirmation will be shown that this has been successful. The updated Vault is now ready to use.

### Vault Column Sorting

While using grids within the Vault, you can now sort the columns by right clicking on the columns name to sort and selecting **Sort Column Ascending** or **Sort Column Descending** from the list.

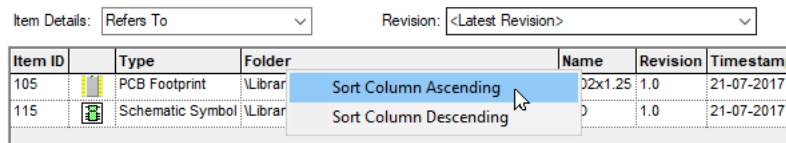

The sorted column(s) will be highlighted using a small up or down arrow:

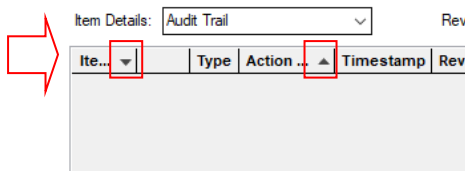

If more than one column is sorted, the priority will be from the left side move across the columns to the right. In the example above, *Items* first then *Actions*.

Once columns have been sorted, right clicking again displays an addition command to **Clear All Column Sorting**. This restores the columns to their original settings.

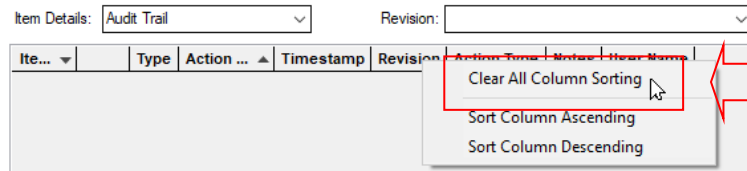

### Sign Out from Vault

In the **Vault Setup** dialog, there is a new **Sign Out** button within the **Sign In** page.

When you press **Sign Out**, your primary and secondary login details will be erased and you will be disconnected from the Vault. In order to continue to use Vault features, you will need to sign back in again.

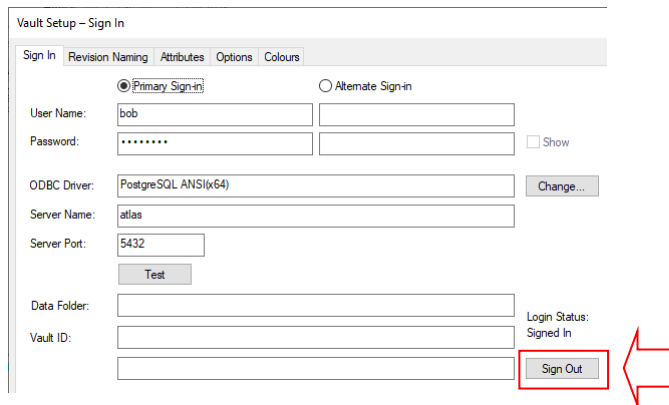

### Changing Vault Column Order

While using grids within the Vault, you can now move and reorder the columns by selecting the cell name and dragging it into the required position.

During the move, the new position will be highlighted with two small red markers:

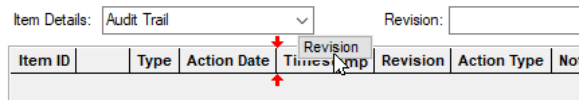

If you wish to reset the columns to their original location, right click on the column header and select **Reset Column Order** from the menu:

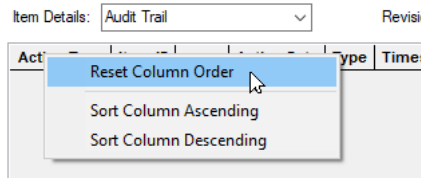

### Splitter Controls in Browser Window

Splitter controls have now been added to the **Browser** page in **Vault Manager** to adjust the sizes of the items grid, details grid, design previews and attributes list. These are indicated when you hover your cursor over the double 'splitter' lines. These sizes are saved to the registry when the page is closed and loaded when it is opened.

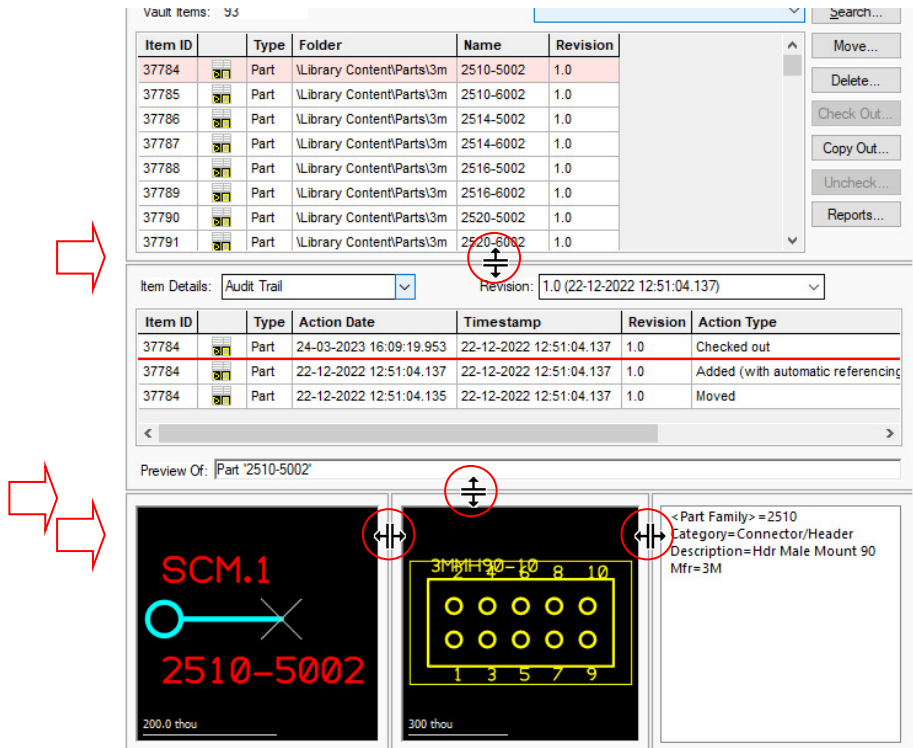

### 'Generic' Files with Vault

You can now check in and out 'generic' files with the Vault. The files can be of any non-Pulsonix data type such as PDF, Gerber, NC Drill, BOMS, Excel/Word documents etc.

Using the new **Generic Files to Vault** page in the **Vault Manager** dialog, you are able to browse for file(s) and check them in. Whilst adding files, you will be prompted to associate the file(s) with an existing vault design. As these files are a non-Pulsonix type, each file must have a unique name (no

duplicates allowed). However, you can overcome this by associating the file to an existing design whereby the name of the file will be unique to that design (you can have multiple files of the same name as long as they are associated with different designs).

There is an additional tab on the dialog for **Generic Files to Vault**:

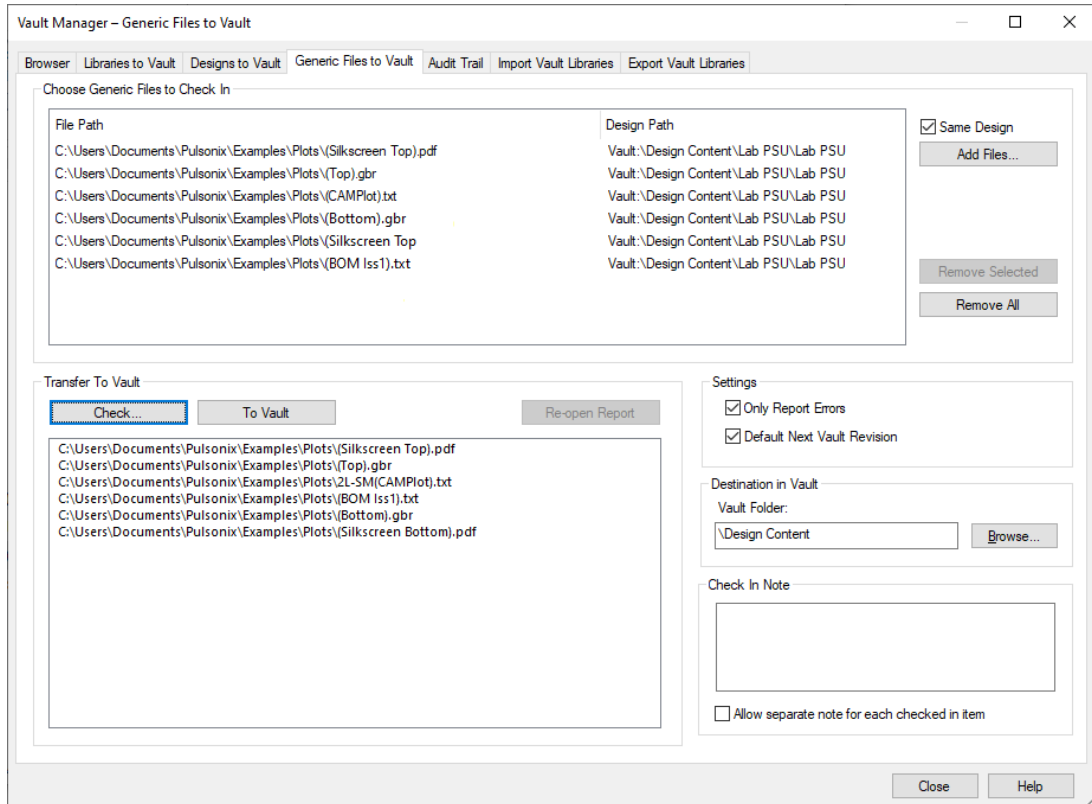

### Transfer Library Data to Vault – New Data Types

You can now transfer **3D Packages** and **STEP Models** as well as existing library types:

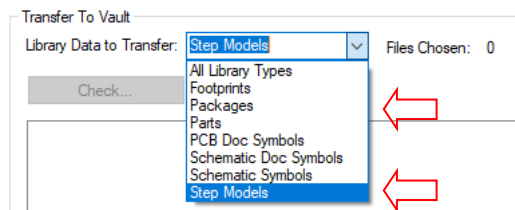



## Find Components by Footprint or Symbol in Vault Speed-up

In the main **Pulsonix Library Manager** on the **Parts** page containing libraries from the **Vault**, if you use the **Find** option and search for all Parts containing a footprint and/or a symbol name matching a specified string, a significant speed-up has been implemented. This new speed-up turns previous search times of an average 2 mins (one reported as 30mins) to mere 1 second.

Note that this speedup is only relevant if you have a Vault that has **cross-referencing** enabled in the **Vault Setup Options** page.

## Show Attributes from Vault Browser

From the **Vault Browser** dialog, there is a new context menu option (when you right click on a selection of parts or footprints from the items grid) called **Show Attributes**.

Vault Items: 123

Item ID	Type	Folder	Name	Revision
40391	Part	\Library Content\Parts\CoilCraft	1008CS-100XGLC	1.0
40392	Part	\Library Content\Parts\CoilCraft	1008CS-100XJLC	1.0
40393	Part	\Libr		
40394	Part	\Libr		
40395	Part	\Libr		
40396	Part	\Libr		
40397	Part	\Libr		
40398	Part	\Libr		

Item Details: Audit Trail

Item ID	Type	Action Date	Timestamp	Revision	Action Type
40393	Part	22-12-2022 12:53:22.175	22-12-2022 12:53:22.175	1.0	Added (with automa
40393	Part	22-12-2022 12:53:22.075	22-12-2022 12:53:22.175	1.0	Moved

When selected, this will open the **Attribute Editor** dialog (in **read-only** mode) which allows you to view the attributes of the selected items. This works the same method as the **Attributes** button from the main **Library Manager** on the **Parts** or **Footprints** page.

### Filter Capability Added to the Check Out from Vault Dialog

The **Check Out** from Vault dialog (access via **Check Out** or **Copy Out** command in Vault toolbar) now allows you to **Filter** the names of items within the vault using names and wildcards.

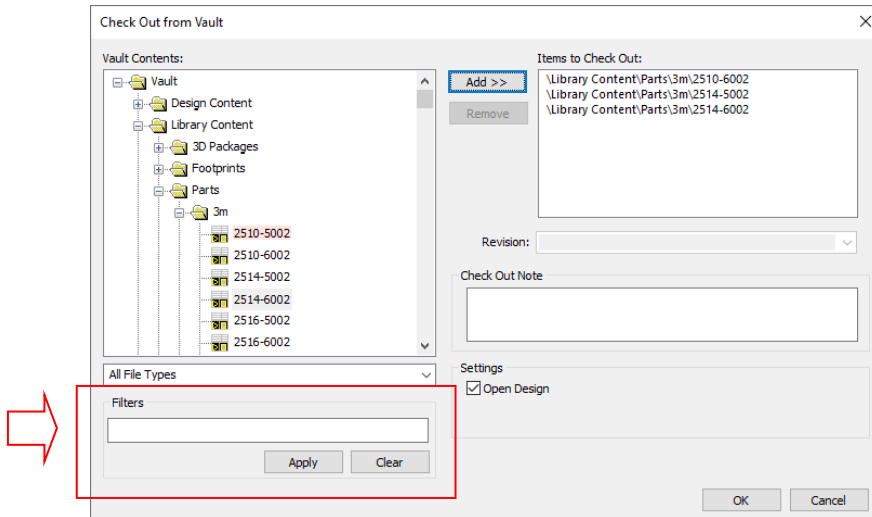

### Execute Attribute Hyperlink

You can now execute hyperlinks from the **Attribute** list in the **Vault Browser** dialog.

To do this, select a Part or Symbol in the Vault Browser dialog, if the item has attributes, the attributes list (bottom right) will fill. If you double-click an attribute defined as a hyperlink (marked in blue), it will open the hyperlink. Alternatively, if you select the attribute and right-click anywhere within the attributes list, it will give you a context menu with the command **Execute Hyperlink** which will open it as well.

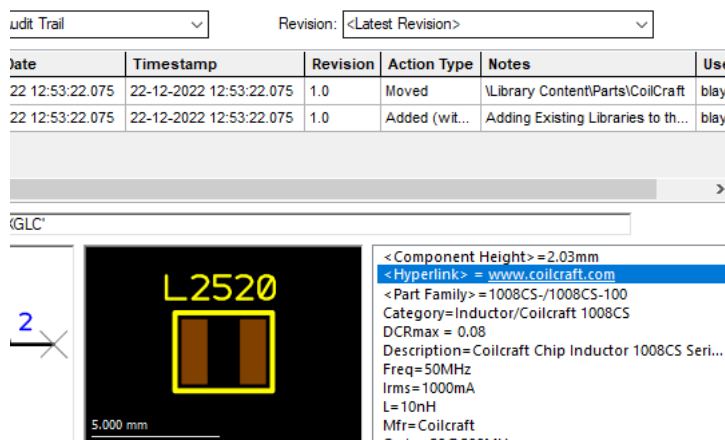

## Check-Out / Copy-Out Vault item using the Vault Toolbar Preselects The Item

With a Design, Symbol or Part editor open, using the **Check Out** or **Copy Out** commands from the Vault toolbar, will now open the **Check Out / Copy Out** dialog and preselect the currently opened Design, Symbol or Part if it is present in the Vault. The open item has to have been checked into the Vault previously and have a Vault ID.

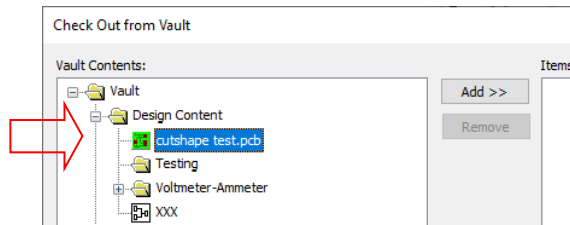

## Import Libraries to Vault

The existing **Export Vault Libraries** feature allows Pulsonix library items to be **exported** from the Vault, usually, to facilitate improved performance when working remotely. The new **Import Vault Libraries** feature allows modifications made to those library items while held in an exported local library to be re-introduced (**imported**) to the Vault in a single operation rather than individually checking in each changed item (both Import and Export are licensed options and will usually be paired).

A new **Import Vault Libraries** page has been added to the **Vault Manager** dialog.

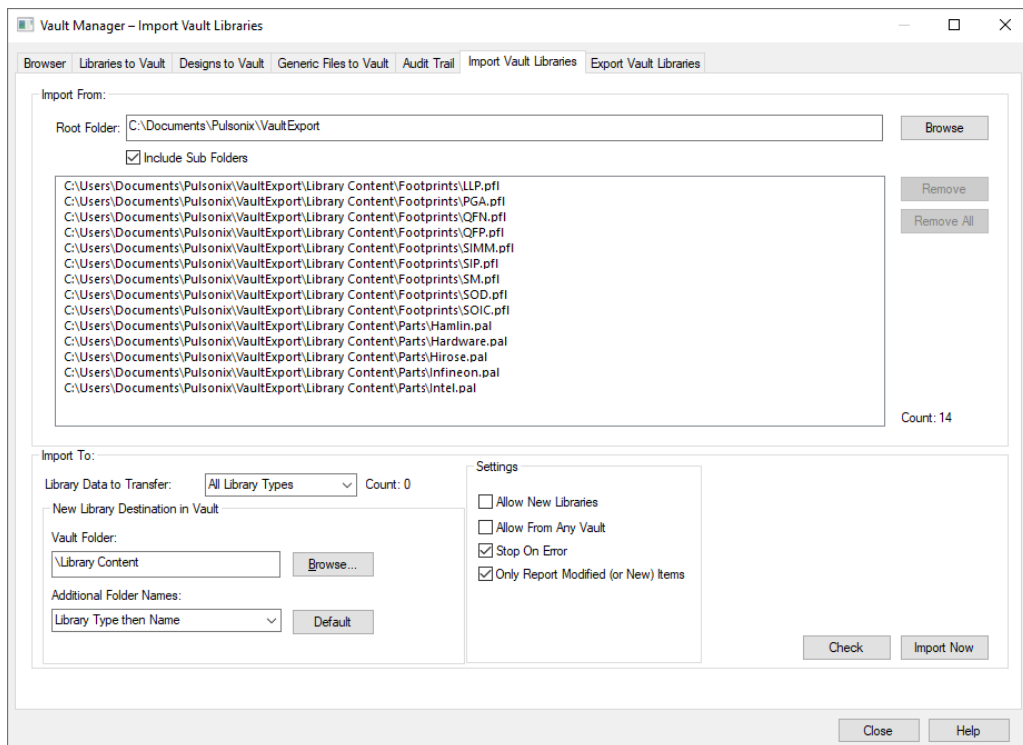

### Special Note

Note: Not importing a full set of changes may mean reloads later. Any modified library items, referencing or referenced by other library items e.g. Footprint or Symbols, not imported at the same time will have to subsequently reload those referenced items before they will be able to be checked into the Vault.

### Using this dialog

From this page, you can browse to the directory that you exported your Vault libraries to, and reintroduce them back into the Vault.

This mechanism will go through the given directory and import any library items that have been changed locally, when compared to the Vault version. Additionally, with the correct settings enabled, it can also add any new library items that were created locally. You can also check to see what changes will be made and any potential errors found by pressing the **Check** button.

## PLM Command File Interface for the new Import Vault Libraries option

There is a new command available in the PLM interface to the Command File Interface called **VaultImport**. This enables the new function in the **Vault, (Import Vault Libraries)**, to be performed through a command line interface.

Optional parameters allow for the override of the options specified from within Pulsonix. By running Pulsonix from the command line with a Pulsonix Command File as a parameter, the Vault Library Import facility can be utilised from the Windows Scheduler to create a regular recurring task. The full recommended command line is shown below:

```
Pulsonix.exe -hidden -commandfile <path to command file>
```

The PLM interface is only available if you have purchased the PLM option.

## Vault Attribute Colours

From the **Vault Setup** dialog under the **Colours** page, there is a new section of controls, that allows you to create **Attribute Colour Rules**.

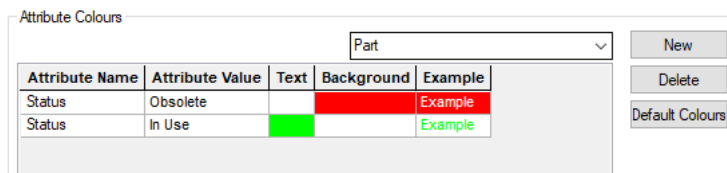

These rules are created by first selecting a Pulsonix data type from the drop down (*Part* in the above example), then selecting an attribute from the in-cell combo box (the attribute must first be associated with the Vault and that data type. Do this from the Vault Attributes Page). Then define an attribute value for which you want the colours to be applied when the item attribute value is equal to this value.

Finally, you can then set the **Text** colour and **Background** colour associated with this new rule. The **Example** box displays how the rule will look when satisfied. When applied, these colour rules will be seen in the **Vault Browser** page where items that have attribute values that match the defined rules will have their grid row painted with the colours chosen.

## Library ToolKit Changes

The Library Toolkit feature has been updated with the following changes:

### Parts Files (.pgf)

**Format 4** in PGF files is now the current format to support the following commands:

Several new commands have been added for PGF files:

```
ADDASSOCPART
SCMPART
REPLACEFOOTPRINT
REPLACESYMBOL
```

Some commands have been renamed:

```
Old NEWPART command has been changed to PART
Old PART command has been changed to PCBPART
```

The **CONNECTOR** command has been changed:

**ADDGATE** will no longer add gates to a part which are created with **CONNECTOR** enabled.

You should still use the **PART** command to create connector parts. As this was the previously named **NEWPART** command so the **SCMSYM** field must now be empty in order to make the part a Connector. If **SCMSYM** field is not blank, the part will not be a Connector and will use the given symbol instead.

More information can be found in the **Library Toolkit Users Guide** on the Pulsonix web site.

## Report Maker Changes

### Change Command Colour and Font / Size

In Report Maker, you now has the ability to change the **Font** and **Font Size**, and the **Colour** of the text in the **Format Script** section (the report script itself). A new **Options** button is available from the main Report Maker dialog:

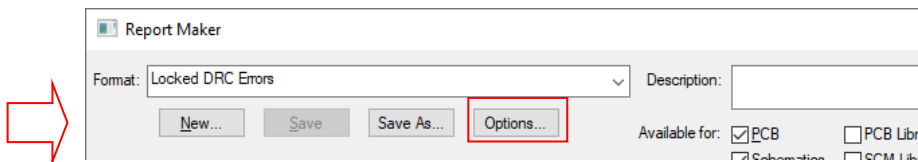

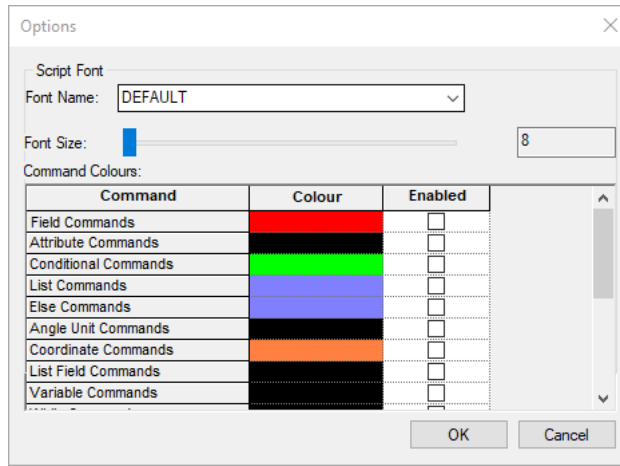

### Change Font

You can change the **Font** using the combo box. The default font used is listed as DEFAULT.

Change **Font Size** using the slider. This will adjust the pixel size. The default is 8. Generally speaking, it is expected that a larger font size will be required due to screen resolution of say, 4K monitors.

### Change Command Colours

In Report Maker, you now has the ability to change the text **colour** of commands in the **Format Script** section (the report script itself), use the new **Options** button.

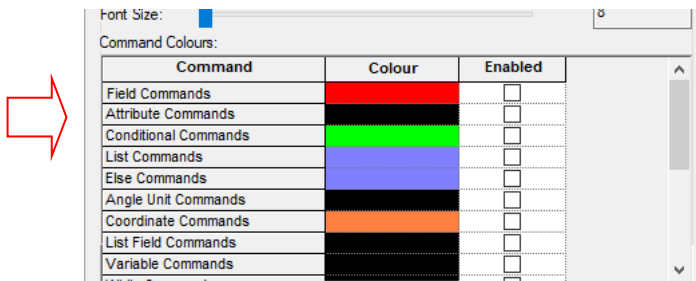

In the grid at the bottom of the dialog, is a list of different command types. For each command type, you can change the **Colour** in which you would like the text to be.

Use the **Enabled** check box on the same row to force this new colour selection. If disabled (unchecked) the default colour will be used.

There are two sets of colours for each command type, one for dark mode and the other for light. These colours can be edited depending on which mode your application is currently set to. For example, you can only change dark mode colours whilst the application is using the dark theme.

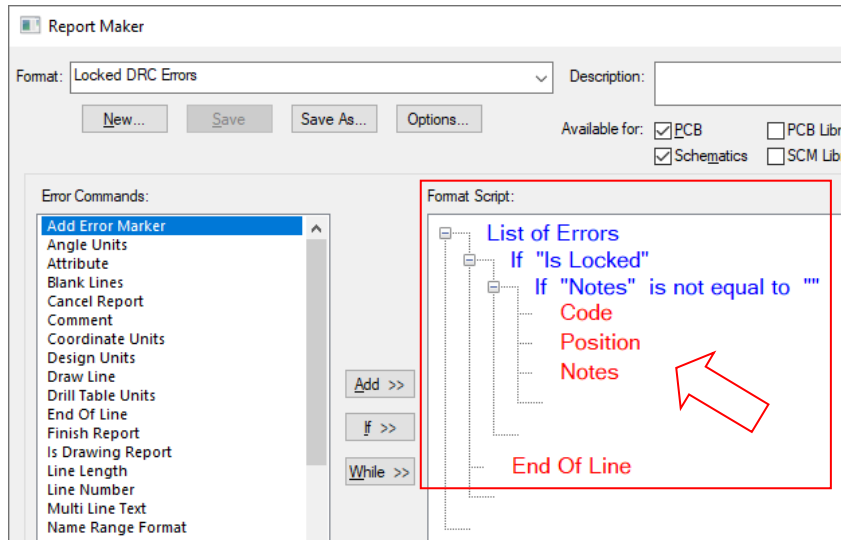

### New command - Symbol Library Path / Name

In Report Maker, you can now report **Current Library Path** and **Name** when doing **List Of Parts** (uses default footprint), **List Of Part Gates**, **List Of Symbol Names** and **List Of Footprint Names** when running from a Parts Library.

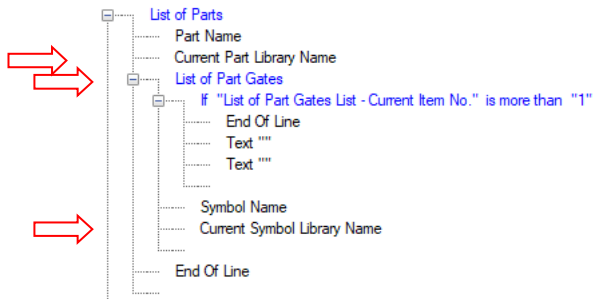

*This feature was back-fitted to V12.0*

### New command - Output to Excel V12.0

A new command has been added to allow the creation of **Excel** format reports.

The new **Excel** command defines the report to be written in and saved as a native binary .xlsx file, (not CSV format).

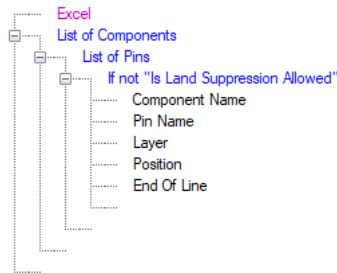

*This feature was back-fitted to V12.0.*

## Network License Server Manager

### Disconnect All Clients

From the **Disconnect Clients** dialog within the **Network License Server Manager (NLSM)** there is a new button named **Disconnect All**. When selected, it will disconnect all users currently connected. This is a easy alternative to selecting individual users and clicking **Disconnect**.

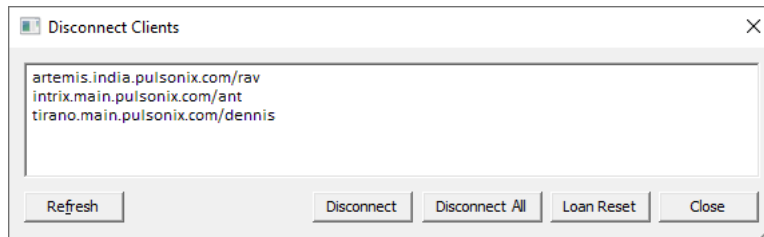

### Disconnect All Clients via Configuration File

A new command can be used in the network licensing configuration file - **DisconnectAllClients**.

When defined with a value between 0 and 2400, the server will automatically disconnect all connected clients at the time defined. For example, adding **DisconnectAllClients 1930** to the configuration file will tell the server to automatically send the disconnect all clients message at 19:30PM. To disable this feature, remove the command from the configuration file or set the time to be 2400.

You can edit the configuration file by opening **NLSM** and going to **Configuration File...** and clicking on the Edit button. If the server is currently running, you will need to press the **Reload** button to ask the server to reload the new changes in the configuration file.

## Scripting Changes

### Import/Export Library Items

New functions have been added to scripting that allow importing a Part/symbol into a library, and exporting a Part/symbol from a library. The functions added are:

PartLibrary – Import (Write a part to the library using the file path of the part)

SymbolLibrary – Import (Write a symbol to the library using the file path of the symbol).



Part – Export (Export the part to the specified directory).

PulsonixDocument – ExportLibraryItem (Export the library item to the specified directory).

Note: Symbols in a library are currently classed as PulsonixDocument's in scripting, not symbols.

*This feature was back-fitted to V12.0.*

### **New AddFootprintFromLibrary and AddFootprintFromLibrary Methods**

New **AddGateFromLibrary** and **AddFootprintFromLibrary** methods on a **Part** object have been added.

Each function is on a Part and it is used to add a Gate or Footprint to the Part from a symbol library. This works in a similar way to how the Insert Gate option works in the Parts editor.

The function tries to find the symbol in the given library and adds it as a gate or footprint to the Part.

It requires the symbol/footprint name and the library name, and if the symbol/footprint is found in the library, it will be added to the Part.

*This has been backfitted to 12.0.*

### **Differential Pair Chains and Signal Paths**

You can now access Differential Pair Chains and Signal Paths through scripting. The following objects have been added:

DiffPairChain – Represents a diff pair chain and allows access to its name, start pads, end pads, a list of all diff pairs in the chain and the maximum length difference and minimum percent paired rule values.

DiffPairChains – A list of all diff pair chains.

SignalPath – Represents a signal path and allows access to its name, start pad, end pad and a list of all the pads in the signal path.

SignalPaths – A list of all signal paths

The function IsInChain has also been added to a DiffPair object to check whether the diff pair is currently part of a chain.

*This feature was back-fitted to V12.0.*

### **Scripting Part for AddGate and Library Close Methods**

A new **AddGate** method on a Part object has been added. It requires the path of a Schematic Symbol, and will add that symbol as a Gate for the Part.

Also added is a new **Close** method for **Part** and **Symbol Libraries**. This allows the library to be manually closed (this was needed as opening a library increments the document count, and he needed it closed to decrement the document count).

*This has been backfitted to 12.0.*

### **New Script Added - Out\_of\_data\_vault\_parts\_in\_designs.vbs**

A new script has been added to the Scripts\Examples folder called **Out\_of\_data\_vault\_parts\_in\_designs.vbs**. When run, the script will search for all PCB or SCM

designs within the given directory and sub-directories. For each design that it discovers, it will run the given report on the design (to be used with **Out of Date Vault Items**) report. The results from these reports will be appended to a single file that is created in the same folder as the script. Once finished, this file will contain the list of Parts from all designs that are not the most up to date revision when compared to the currently connected Vault.

There is a section in the **Report Maker - Vault Commands** help page that discusses how to use the script.

### Progress Indicator on Taskbar Icon

The current state of any progress bar is now displayed on the taskbar icon for Pulsonix. This means the progress can be seen even when Pulsonix is minimised. This is particularly useful if long longs are being performed, such as a DRC on a very large design.

The Pulsonix icon will show a green slider moving across as the option progresses.



### Dynamic Design Verify Improvements

#### Enable Dynamic Verify

When instructed by your local service office, Dynamic Verify is now performed in a different thread so that it has little to no impact on normal usage of Pulsonix. This means it is much more practical to have all checks enabled so that the design is verified constantly while changes are being made.

This option is enabled from the **File** menu, **Document Properties** and **Statistics** page and using the **Enable Dynamic Verify** button.

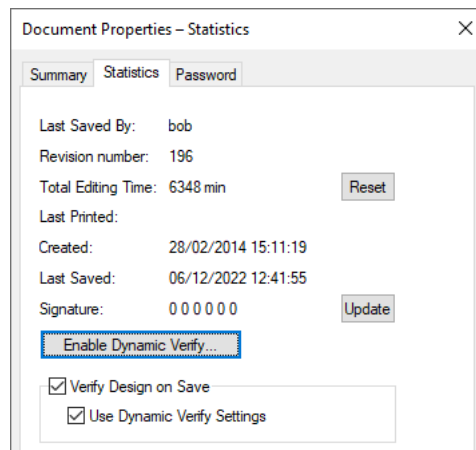

New options enable **Verify Design on Save**, which when selected, is used for verifying the design whenever a save is performed (note: this is only Save and not on a Save As). On large designs this can significantly slow down saving if verifying takes a while. Use the **Use Dynamic Verify Settings**

switch to only check for the Dynamic Verify faults instead of every fault if you wish. This can help speed it up.

Within the **Enable Dynamic Verify** dialog, there is a button to quickly **Enable All** checks and a button to **Verify** the design with the currently enabled checks. On large designs this can significantly slow down saving if verifying takes a while. There is another switch to only check for the Dynamic Verify faults instead of every fault if you wish; this can speed things.

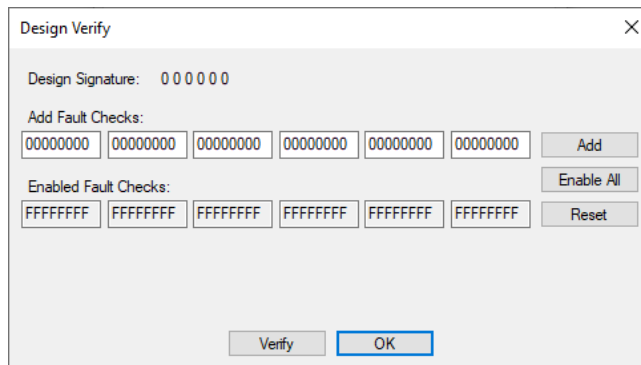

When running on larger designs, a progress bar to show how far the verify has progressed is displayed. A message to show the current signature of the design is also displayed.

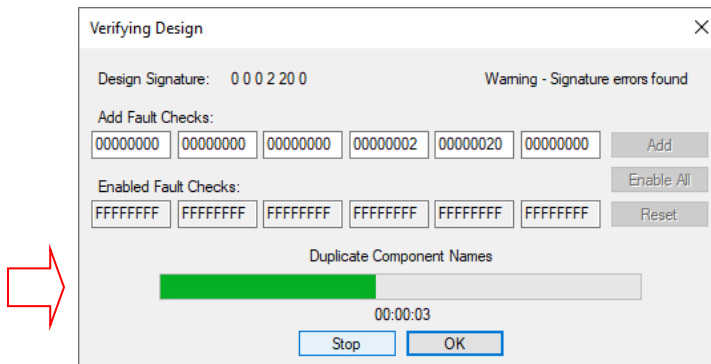

A report is produced once completed showing you any errors:

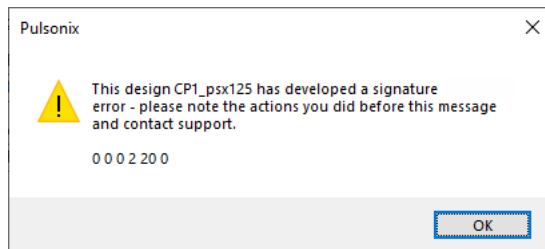

A small icon on the right side of the status bar will display the current status of the Dynamic Verify once enabled.

A green tick shows the design is free of signature errors.

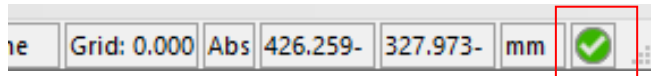

A red exclamation mark indicates the presence of errors, and a spinning circle is used when the design is currently being verified in the background.

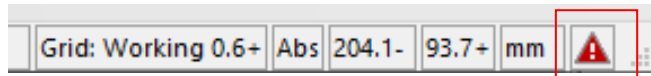

This icon can also be double-clicked to display the **Dynamic Verify** Dialog.

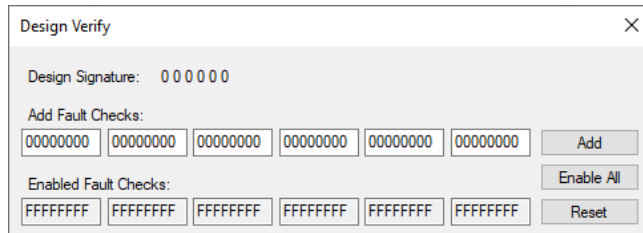

Designs now store their last signature result which can be checked when opening the design and can be used to tell if the signature error has suddenly got worse (or better!)

## Memory Dumps

Under certain extreme circumstances, if you encounter the 'Pulsonix has encountered an error' window, this now has an option to save a memory dump of the error to a temporary location on your local machine. The dump file (.dmp) can be sent along with an up-to-date support file (which is generated at the same time in the same folder) to Pulsonix support to help them find the cause of the error and fix it.

Depending on the design size and complexity, this process can take some time to create the dump. This could be in the hours if the design is very large, so be aware. Once complete, a window will appear to tell you where the file was saved to.

*This was backfitted to V12.0.*